

## UNDERSTANDING THE ISSUES

The preservative-treated wood industry has voluntarily moved away from the use of Chromated Copper Arsenate (CCA-C) for residential and general consumer use.

Testing has shown that additional corrosion protection is required for fasteners and connectors in contact with some of the alternative preservative wood treatments which are generally more corrosive than CCA-C.

Simpson Strong-Tie recommends the use of stainless-steel fasteners, anchors and connectors with treated wood as the most effective solution to corrosion risk. However, stainless steel is also more expensive and sometimes more difficult to obtain. In some cases, customers can use ZMAX® coating (G185 per ASTM A653), hot-dip

galvanized (HDG) (per ASTM A123 for connectors and ASTM A153 for fasteners), or mechanically galvanized fasteners and anchors (per ASTM B695, Class 55 or greater) with some treated woods. (See technical bulletin T-PTWOOD for specific recommendations).

Simpson Strong-Tie continues efforts to provide additional alternatives; testing was performed which evaluated the performance of applying a barrier membrane between the connector and the treated wood.

The only barrier membrane tested in this study was Grace Vycor® Deck Protector™.

Other barrier membranes may be evaluated. Visit [www.strongtie.com/info](http://www.strongtie.com/info) for the latest information.

The following information is a summary of the testing performed by Simpson Strong-Tie® and Grace Construction Products, and the resulting conclusions related to the use of Grace Vycor® Deck Protector™ and connectors in contact with various preservative-treated woods. The information is intended to help aid in the selection of coatings provided on connectors and fasteners that are in contact with preservative-treated wood.

See technical bulletin T-PTWOOD for additional corrosion information developed from previous testing conducted by Simpson Strong-Tie. We continue to research this evolving topic. Stay informed by visiting [www.strongtie.com/info](http://www.strongtie.com/info) for the very latest information.

## SCOPE OF TESTING

Barrier membrane corrosion testing was conducted by Grace Construction Products in conformance with ASTM G59 "Standard Test Method for Conducting Potentiodynamic Polarization Resistance Measurements." Simpson Strong-Tie also conducted barrier membrane corrosion testing in general conformance<sup>1</sup> with the American Wood Preservers Association Standard E12-94 "Standard Method of Determining Corrosion of Metal in Contact With Treated Wood".

1. The E12 standard requires the use of 1"x2" steel coupons; 2"x3" steel coupons were used in this testing.

All test samples used steel coupons with a hot-dip galvanized coating conforming to ASTM A653 G90 (0.90 oz/ft<sup>2</sup> of zinc total both sides). The tested preservative-treated woods included Chromated Copper Arsenate Type C (CCA-C), Alkaline Copper Quat Type D Carbonate (ACQ-D Carbonate), and Copper Azole Type B (CA-B). The ACQ-D and CA-B treatments used an ammonia carrier.

## TEST RESULTS

The following figure represents a general summary of some of the test results.

Due to the similarity in the relative corrosion rates of ACQ-D (Carbonate) and CA-B treated wood on galvanized steel, the data from these two treatments were grouped and analyzed together.

**Figure 1** compares the average tested relative corrosiveness of the alternative treatments with and without the barrier membrane to the corrosion which occurred with unprotected CCA-C treated wood. The results shown are based on this testing and may or may not have a relation to actual service life.

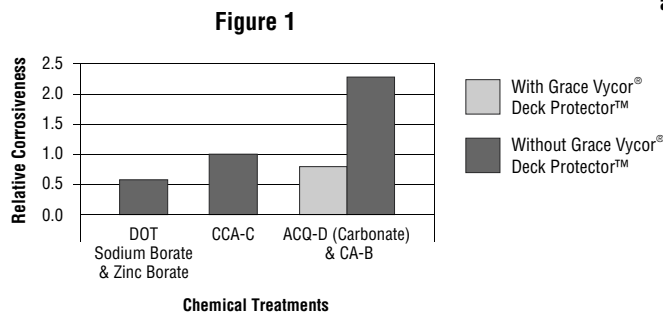

**From Figure 1 the following observations are made from the test results:**

- ACQ-D (Carbonate) and CA-B treated wood without the Grace Vycor® Deck Protector™ barrier membrane is on the average approximately two times more corrosive than CCA-C treated wood.
- DOT Sodium Borate and Zinc Borate are less corrosive than CCA-C.
- ACQ-D (Carbonate) and CA-B treated woods used in conjunction with the Grace Vycor® Deck Protector™ barrier membrane are less corrosive than CCA-C treated wood.

## KEY FINDINGS (See page 4 for additional conclusions):

- In some cases, Grace Vycor® Deck Protector™ can be used with G90 galvanized connectors, as an alternative to ZMAX coating or post hot-dip galvanized (HDG) connectors. Refer to chart on page 2 for specific recommendations.
- ACQ-D (Carbonate) and CA-B treated woods used in conjunction with the Grace Vycor® Deck Protector™ barrier membrane are less corrosive than CCA-C treated wood.
- When using a barrier with G90, ZMAX coating or HDG connectors, hot-dip galvanized fasteners (ASTM A153) must be used.
- Grace Vycor® Deck Protector™ is not recommended for use with stainless steel fasteners or connectors.

**800-999-5099**  
**[www.strongtie.com](http://www.strongtie.com)**

©2008  
Simpson Strong-Tie Company Inc.  
Printed in the U.S.A.

T-PTBARRIER08-R 11/08 exp. 1/11  
**12/12**

# BARRIER MEMBRANES & PRESERVATIVE-TREATED WOOD

## GUIDELINES FOR SELECTING THE PROPER CONNECTOR

### 1 Evaluate the Application.

Consider the type of structure and how it will be used. These recommendations may not apply to non-structural applications such as fences.

### 2 Evaluate the Environment

Testing and experience indicate that indoor dry environments are less corrosive than outdoor environments. Determining the type of environment where a connector or fastener will be used is an important factor in selecting the connectors and fasteners of the most appropriate material or with the most appropriate coating. To help in your decision making, consider the following general exposure information:

**Interior Dry Use:** Includes wall and ceiling cavities, and raised-floor applications of enclosed buildings that have been designed to ensure that condensation and other sources of moisture do not develop.

**Exterior - Dry:** Includes outdoor installations in low-rainfall environments and no regular exposure to moisture.

**Exterior - Wet:** Includes outdoor installations in higher moisture and rainfall environments.

**Higher Exposure Use:** Includes exposure to ocean salt air, fire retardants, large bodies of water, fumes, fertilizers, soil, some preservative-treated woods, industrial zones, acid rain, and other corrosive elements. Type 316 stainless steel contains slightly more nickel than other grades, plus 2–4% molybdenum, giving it better corrosion resistance in high chloride environments.

### 3 Evaluate and select a suitable preservative-treated wood for the intended application and environment.

The treated wood supplier should provide all the information needed regarding the wood being used. This information should include: the specific type of wood treatment used, if ammonia was used in the treatment, and the chemical retention level. If the needed information is not provided then Simpson Strong-Tie would recommend the use of stainless-steel connectors and fasteners without a barrier membrane. You should also ask the treated wood supplier for a connector coating or material recommendation.

### 4 Use the chart on the right, which was created based on Simpson Strong-Tie testing and experience to select the connector finish or material.

If a treated wood product is not identified on the chart, Simpson Strong-Tie has not evaluated test results regarding such product and therefore cannot make any recommendation other than the use of stainless steel without a barrier membrane with that product. Manufacturers may independently provide test results or other product use information; Simpson Strong-Tie expresses no opinion regarding any such information.

### 5 Compare the treated wood supplier's recommendation with the Simpson Strong-Tie recommendation.

If these recommendations are different, Simpson Strong-Tie recommends that the most conservative recommendation be followed.

## For Selection When Using A Barrier Membrane

**Low** = Use Simpson Strong-Tie® standard painted and G90 galvanized connectors as a minimum. Use fasteners galvanized per ASTM A153 or SDS screws with double-barrier coating.

**Med** = Use ZMAX®/ HDG galvanized connectors as a minimum. Use fasteners which meet the specifications of ASTM A153 or SDS screws with double-barrier coating.

**High** = Use Type 303, 304, 305 or 316 stainless steel connectors and fasteners<sup>8</sup>. Do not use a barrier membrane.

Connector Coating Recommendation When Using a Barrier Membrane - Structural Applications<sup>7</sup>

Environment	SBX/DOT & Zinc Borate <sup>5</sup>	MCQ	ACQ-C, ACQ-D (Carbonate), CA-B, CBA-A			ACZA	Other or Uncertain
			No Ammonia	With Ammonia	Higher Chemical Content <sup>1</sup>		
Interior - Dry	Not Needed <sup>6</sup>	Low	Low	Low	High	High	High
Exterior - Dry	N/A <sup>2</sup>	Med <sup>3,4</sup>	Med <sup>3,4</sup>	High	High	High	High
Exterior - Wet	N/A <sup>2</sup>	Med <sup>3,4</sup>	Med <sup>3,4</sup>	High	High	High	High
Higher Exposure	N/A <sup>2</sup>	High	High	High	High	High	High
Uncertain	N/A <sup>2</sup>	High	High	High	High	High	High

1. Woods with actual retention levels greater than 0.40 pcf for ACQ and MCQ, 0.41 pcf for CBA-A, or 0.21 pcf for CA-B (Ground Contact level).
2. Borate treated woods are not appropriate for outdoor use.
3. Test results indicate that ZMAX/HDG and the SDS double-barrier coating will perform adequately, subject to regular maintenance and periodic inspection. However, the nationally-approved test method used, AWWA E12-94, is an accelerated test, so data over an extended period of time is not available. If uncertain, use stainless steel.
4. Some treated wood may have excess surface chemicals making it potentially more corrosive. If you suspect this or are uncertain, use stainless steel.
5. Zinc Borate is a preservative treatment for wood composites.
6. SBX/DOT Sodium Borate and Zinc Borate are less corrosive than CCA-C. Therefore using G90 galvanized connectors without a barrier is appropriate.
7. See technical bulletin T-PTWOOD for recommendations on applications that do not use a barrier membrane.
8. Type 316 stainless-steel connectors are the minimum recommendation for ocean salt air and other chloride environments.

**BARRIER MEMBRANES & PRESERVATIVE-TREATED WOOD**

**INSTALLATION DETAILS**

**Installation Instructions:**

- Refer to chart on page two to determine appropriate connector finish for your application.
- Apply barrier membrane in fair weather when the air, surface and barrier are at 25° F or higher.
- Install onto a clean surface.
- Cut to the desired length.
- Peel the release paper, align the membrane and press into place with heavy hand pressure.
- Install the barrier such that all laps shed water.
- Install Simpson Strong-Tie® connector with hot-dip galvanized (HDG) fasteners (per ASTM A153) or SDS screws with a double-barrier coating.
- With barrier membrane, do not use standard (brite) or stainless steel fasteners.
- Due to its slight asphaltic odor, do not leave Grace Vycor® Deck Protector™ exposed to interior living spaces (per Grace product recommendation).
- Trim barrier around connector as required by Grace Construction Products.
- See [www.na.graceconstruction.com/deckprotector](http://www.na.graceconstruction.com/deckprotector) for additional installation instructions and other requirements.

**Interior, Dry Use**

**Typical Hanger Installation with Solid Sawn Wood**

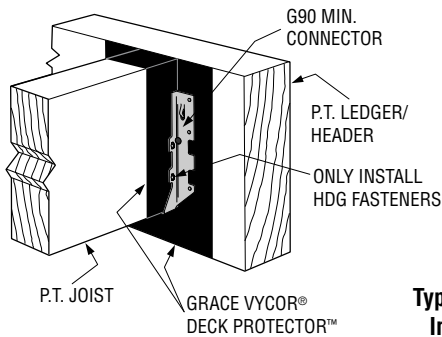

**Typical Hanger Installation with Composite Wood**

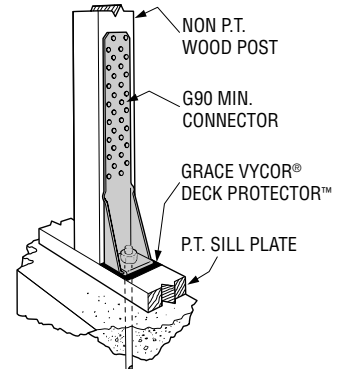
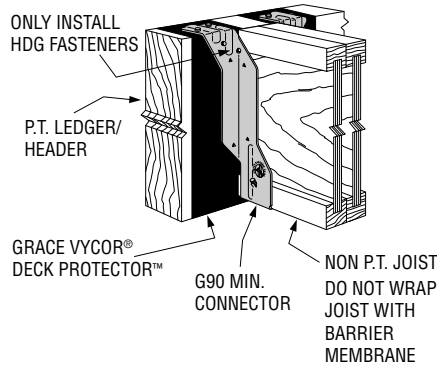

**Typical Holdown Installation (Mudsill connector applications similar)**

**Typical Ledger Installation**

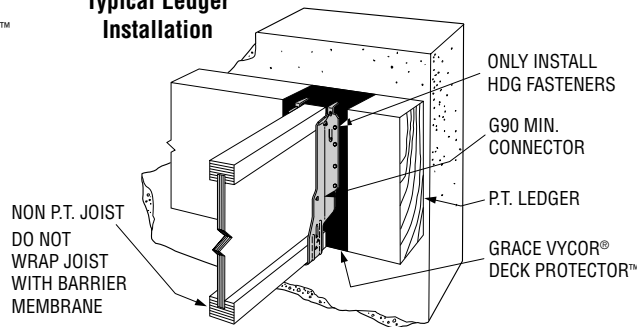

**Exterior Use (No ammonia)**

**Typical Exterior Hanger Installation with Solid Sawn Wood**

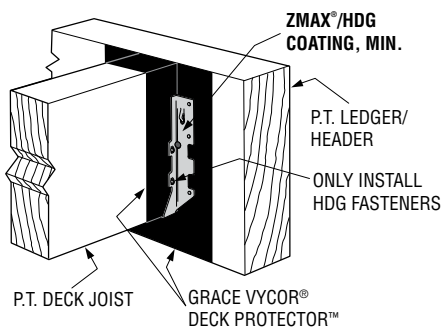

**Typical Exterior Post Base Installation**

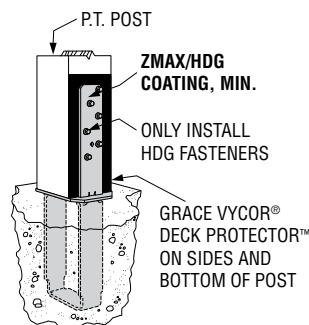

**Typical Exterior Post Base Installation with Trim**

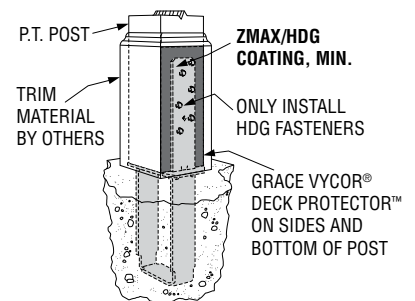

P.T. = Preservative-Treated Wood; MIN = Minimum

## CONCLUSIONS

- To obtain maximum corrosion benefit, proper installation is required.
- Test results may or may not have a relation to actual service life.
- Use only hot-dip galvanized fasteners (ASTM A153) with ZMAX<sup>®</sup> and HDG coated connectors.
- Do not use Grace Vycor<sup>®</sup> Deck Protector<sup>™</sup> with stainless-steel fasteners or connectors.
- When using a barrier with G90, ZMAX or HDG galvanized connectors, hot-dip galvanized fasteners (ASTM A153) or SDS screws with double barrier coating must be used.
- This research indicates that Grace Vycor<sup>®</sup> Deck Protector<sup>™</sup> can be an option, under appropriate circumstances, in providing additional corrosion protection when applied between certain preservative-treated woods and metal connectors.
- ACQ-D (Carbonate) and CA-B treated woods used in conjunction with the Grace Vycor<sup>®</sup> Deck Protector<sup>™</sup> barrier membrane are less corrosive than CCA-C treated wood.
- For Interior, Dry applications Simpson Strong-Tie<sup>®</sup> standard G90 galvanized connectors in conjunction with Grace Vycor<sup>®</sup> Deck Protector<sup>™</sup> barrier membrane can be used as an alternative to ZMAX or HDG galvanized connectors, as shown in the Recommendation Chart on page two.
- Hot, arid environments may require a different barrier membrane solution. Consult [www.na.graceconstruction.com/deckprotector](http://www.na.graceconstruction.com/deckprotector) for product information.
- Stainless steel is always recommended for Higher Exposure use, including exposure to ocean salt air, large bodies of water, fumes, fertilizers, and some preservative treated woods (see Recommendation Chart on page 2).
- By selecting products that offer more corrosion protection, you can extend the service life of your connectors. However, corrosion will still occur. For wood with actual retention levels greater than 0.40 pcf for ACQ, MCQ and ACZA, 0.41 pcf for CBA-A, or 0.21 pcf for CA-B (Ground Contact level), stainless steel connectors and fasteners without a barrier membrane are recommended. Verify actual retention level with the wood treater. Due to the many variables involved, Simpson Strong-Tie cannot provide estimates on service life of any connectors, fasteners, or anchors.
- See technical bulletin T-PTWOOD for additional information.
- This technical bulletin does not alter testing conclusions reached in earlier bulletins.

*This bulletin is effective until ~~January 31, 2011~~, and reflects information available as of November 1, 2008. This information is updated periodically and should not be relied upon after ~~January 31, 2011~~; contact Simpson Strong-Tie for current information and limited warranty or see [www.strongtie.com](http://www.strongtie.com).*

Simpson Strong-Tie Co. Inc.  
P.O. Box 10789  
Pleasanton, CA 94588

800-999-5099  
[www.strongtie.com](http://www.strongtie.com)

©2008  
Simpson Strong-Tie Company Inc.  
Printed in the U.S.A.

T-PTBARRIER08-R 11/08 exp. 1/11  
12/12