

STEEL STRONG-WALL®: Anchorage Solutions

SSWAB ANCHOR BOLTS

SSWAB anchor bolts in ¾" and 1" diameters offer flexibility to meet specific project demands. Inspection is easy; the head is stamped with a "No Equal" symbol for identification, bolt length, bolt diameter, and optional "HS" for High Strength if specified.

MATERIAL: ASTM F1554 Grade 36; High Strength (HS) ASTM A449

An additional nut for template installation is provided with each SSWAB. It may also be used for SSW installation.

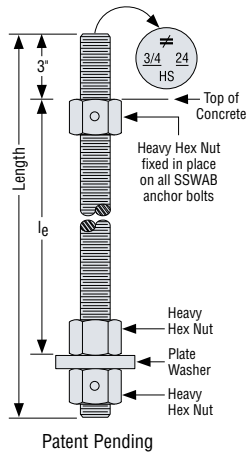

Steel Strong-Wall Width (in)	Model No.	Dia. (in)	Total Length (in)	le (in)
12" Model	SSWAB¾x24	¾	24	19
	SSWAB¾x24HS	¾	24	19
	SSWAB¾x30	¾	30	25
	SSWAB¾x30HS	¾	30	25
	SSWAB¾x36HS	¾	36	31
15", 18", 21", 24" Models	SSWAB1x24	1	24	19
	SSWAB1x24HS	1	24	19
	SSWAB1x30	1	30	25
	SSWAB1x30HS	1	30	25
	SSWAB1x36HS	1	36	31

SSWHSR EXTENSION KIT

SSWHSR allows for anchorage in tall stemwall applications where full embedment of an SSWAB into the footing is required. The head is stamped for identification like an SSWAB. Kit includes ASTM A449 high-strength rod with heavy hex nut fixed in place and high strength coupler nut. Do not use in place of SSWAB.

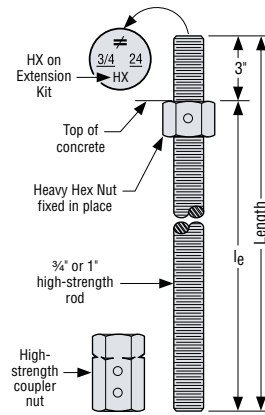

SSWHSR_KT
Patent Pending

$$\text{Total } l_e = \text{SSWHSR } l_e + \text{SSWAB } l_e + 3"$$

Steel Strong-Wall Width (in)	Model No.	Dia. (in)	Total Length (in)	le (in)
12" Model	SSWHSR¾x2KT	¾	24	21
	SSWHSR¾x3KT	¾	36	33
15", 18", 21", 24" Models	SSWHSR1x2KT	1	24	21
	SSWHSR1x3KT	1	36	33

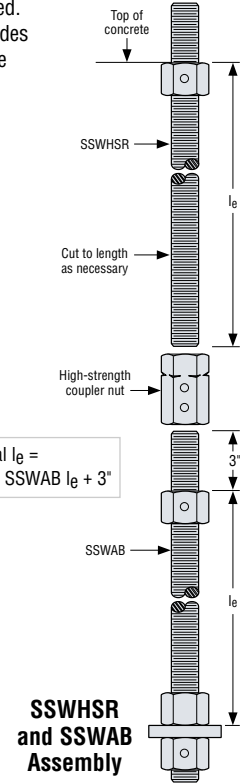

STEEL STRONG-WALL® ANCHORAGE SOLUTIONS – 2500 psi CONCRETE

Design Criteria	Concrete Condition	Anchor Strength	SSWAB ¾" ANCHOR BOLT			SSWAB 1" ANCHOR BOLT		
			ASD Allowable Uplift (lbs)	W (in)	de (in)	ASD Allowable Uplift (lbs)	W (in)	de (in)
Seismic	Cracked	Standard	9600	25	9	17100	36	12
		High Strength	19900	39	13	35300	56	19
	Uncracked	Standard	9600	21	7	17100	32	11
		High Strength	19900	34	12	35300	49	17
Wind	Cracked	Standard	4500	12	6	5600	14	6
			6900	16	6	12700	24	8
			9600	20	7	17100	30	10
		High Strength	11100	22	8	22400	35	12
			13500	25	9	26800	39	13
			16000	28	10	31600	43	15
			19900	33	11	35300	47	16
	Uncracked	Standard	5600	12	6	5600	12	6
			7800	15	6	12000	20	7
			9600	18	6	17100	26	9
		High Strength	11200	19	7	22100	30	10
			13900	22	8	26700	34	12
			15800	24	8	32100	38	13
			19900	29	10	35300	41	14

- See pages 35-36 for foundation illustrations showing W and de dimensions.
- Anchorage designs conform to ACI 318 Appendix D with no supplementary reinforcement and cracked or uncracked concrete as noted.
- Anchor strength indicates required grade of SSWAB anchor bolt. Standard or High Strength (HS).
- Seismic indicates Seismic Design Category C through F. Detached 1 and 2 family dwellings in SDC C may use wind anchorage solutions. Seismic anchorage designs conform to ACI 318-05 Section D.3.3.4.
- Wind includes Seismic Design Category A and B.
- Foundation dimensions are for anchorage only. Foundation design (size and reinforcement) by Designer. The registered design professional may specify alternate embedment, footing size or anchor bolt.

STEEL STRONG-WALL®: Anchorage Solutions

STEEL STRONG-WALL® ANCHORAGE SOLUTIONS – 3500 psi CONCRETE

Design Criteria	Concrete Condition	Anchor Strength	SSWAB ¾" ANCHOR BOLT			SSWAB 1" ANCHOR BOLT		
			ASD Allowable Uplift (lbs)	W (in)	d _e (in)	ASD Allowable Uplift (lbs)	W (in)	d _e (in)
Seismic	Cracked	Standard	9600	22	8	17100	33	11
		High Strength	19900	36	12	35300	51	17
	Uncracked	Standard	9600	19	7	17100	28	10
		High Strength	19900	31	11	35300	44	15
Wind	Cracked	Standard	5300	12	6	6000	13	6
			7400	15	6	13200	22	8
			9600	18	6	17100	27	9
		High Strength	11400	20	7	23100	32	11
			14100	23	8	27800	36	12
			15900	25	9	31700	39	13
	Uncracked	Standard	19900	30	10	35300	43	15
			6600	12	6	6600	12	6
			8300	14	6	12200	18	6
		High Strength	9600	16	6	17100	23	8
			11200	17	6	22400	27	9
			14300	20	7	27500	31	11
			16400	22	8	33100	35	12
			19900	26	9	35300	37	13

- See pages 35-36 for foundation illustrations showing W and d_e dimensions.
- Anchorage designs conform to ACI 318 Appendix D with no supplementary reinforcement and cracked or uncracked concrete as noted.
- Anchor strength indicates required grade of SSWAB anchor bolt. Standard or High Strength (HS).
- Seismic indicates Seismic Design Category C through F. Detached 1 and 2 family dwellings in SDC C may use wind anchorage solutions. Seismic anchorage designs conform to ACI 318-05 Section D.3.3.4.
- Wind includes Seismic Design Category A and B.
- Foundation dimensions are for anchorage only. Foundation design (*size and reinforcement*) by Designer. The registered design professional may specify alternate embedment, footing size or anchor bolt.

STEEL STRONG-WALL® ANCHORAGE SOLUTIONS – 4500 psi CONCRETE

Design Criteria	Concrete Condition	Anchor Strength	SSWAB ¾" ANCHOR BOLT			SSWAB 1" ANCHOR BOLT		
			ASD Allowable Uplift (lbs)	W (in)	d _e (in)	ASD Allowable Uplift (lbs)	W (in)	d _e (in)
Seismic	Cracked	Standard	9600	20	7	17100	30	10
		High Strength	19900	33	11	35300	47	16
	Uncracked	Standard	9600	18	6	17100	26	9
		High Strength	19900	28	10	35300	41	14
Wind	Cracked	Standard	6000	12	6	6000	12	6
			7600	14	6	12900	20	7
			9600	17	6	17100	25	9
		High Strength	11000	18	6	22600	29	10
			13900	21	7	27400	33	11
			17000	24	8	31500	36	12
	Uncracked	Standard	19900	27	9	35300	40	14
			7500	12	6	7500	12	6
			8500	13	6	12700	17	6
		High Strength	9600	15	6	17100	22	8
			10500	15	6	22600	25	9
			13800	18	6	26800	28	10
			16200	20	7	32700	32	11
			19900	24	8	35300	35	12

- See pages 35-36 for foundation illustrations showing W and d_e dimensions.
- Anchorage designs conform to ACI 318 Appendix D with no supplementary reinforcement and cracked or uncracked concrete as noted.
- Anchor strength indicates required grade of SSWAB anchor bolt. Standard or High Strength (HS).
- Seismic indicates Seismic Design Category C through F. Detached 1 and 2 family dwellings in SDC C may use wind anchorage solutions. Seismic anchorage designs conform to ACI 318-05 Section D.3.3.4.
- Wind includes Seismic Design Category A and B.
- Foundation dimensions are for anchorage only. Foundation design (*size and reinforcement*) by Designer. The registered design professional may specify alternate embedment, footing size or anchor bolt.

STEEL STRONG-WALL®: Anchorage Solutions

STEEL STRONG-WALL® SHEAR ANCHORAGE

Foundation shear reinforcement to resist shear forces from Strong-Wall® panels located at the edge of concrete is shown in the table below. The SSW12 and SSW15 used in wind applications do not require shear reinforcement when the panel design shear force is less than the anchorage allowable shear load shown in the table below.

Model	Lt or Lh (in)	SEISMIC ³		WIND ⁴		ASD Allowable Shear Load V ⁶ (lbs)			
		Shear Reinforcement	Minimum Curb/Stemwall Width (in)	Shear Reinforcement	Minimum Curb/Stemwall Width (in)	6" Minimum Curb/Stemwall		8" Minimum Curb/Stemwall	
						Uncracked	Cracked	Uncracked	Cracked
SSW12	9	(1) #3 Tie	6	None required	—	1370	980	1605	1145
SSW15	12	(1) #3 Tie	6	None required	—	1765	1260	2015	1440
SSW18	14	(1) #3 Hairpin	8 ⁵	(1) #3 Hairpin	6	Hairpin reinforcement achieves maximum allowable shear load of the Steel Strong-Wall® panel.			
SSW21	15	(1) #3 Hairpin	8 ⁵	(1) #3 Hairpin	6				
SSW24	17	(2) #3 Hairpins	8 ⁵	(2) #3 Hairpins	6				

1. Shear anchorage designs conform to ACI 318-05 and assume minimum $f'_c = 2500$ psi concrete. See pages 32-33 for tension anchorage.
2. Shear reinforcement is not required for panels installed on a wood floor, interior foundation applications (panel installed away from edge of concrete), or braced-wall panel applications.
3. Seismic indicates Seismic Design Category C through F. Detached 1 and 2 family dwellings in SDC C may use wind anchorage solutions. Seismic shear reinforcement designs conform to ACI 318-05 Section D.3.3.4.
4. Wind includes Seismic Design Category A and B.
5. Where noted minimum curb/stemwall width is 6" when standard-strength SSWAB is used.
6. Use (1) #3 tie for SSW12 and SSW15 when the Steel Strong-Wall® panel design shear force exceeds the tabulated anchorage allowable shear load.
7. The registered design professional may specify alternate shear anchorage.

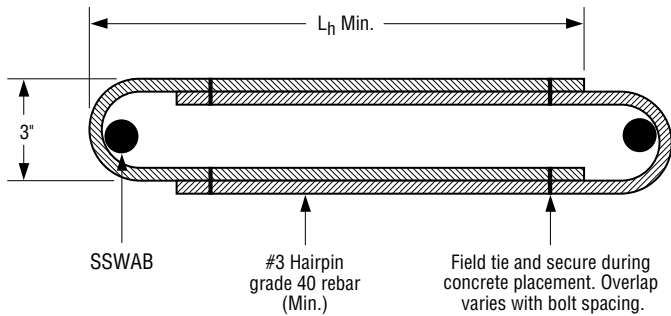

Hairpin Shear Reinforcement

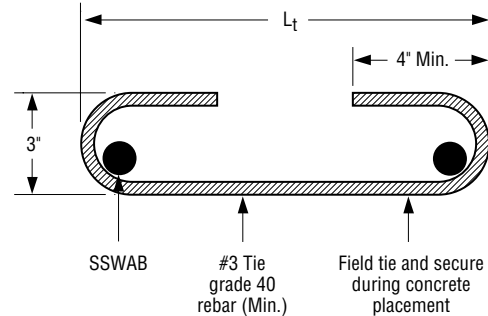

Tie Shear Reinforcement

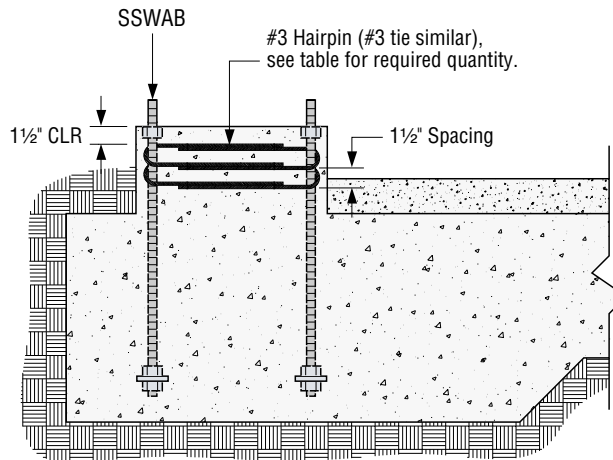

Hairpin Installation

(Garage curb shown, other footing types similar)

STEEL STRONG-WALL®: Anchorage Solutions

CURB OR STEMWALL INSTALLATION

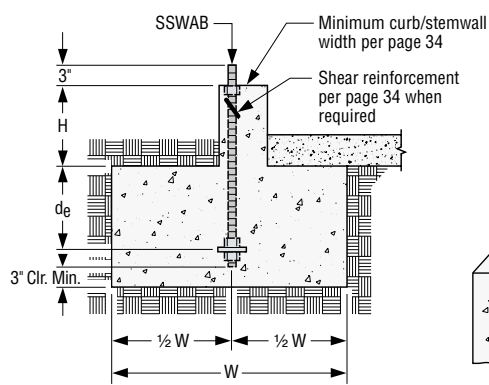

Curb or Stemwall Section View

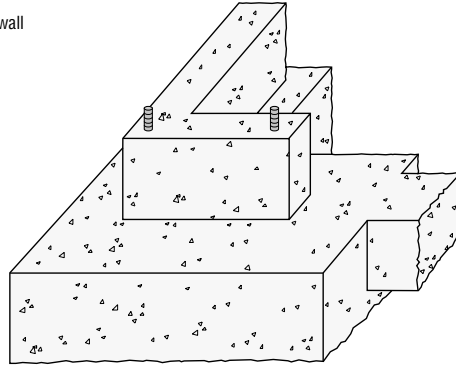

Perspective View
(Slab not shown for clarity)

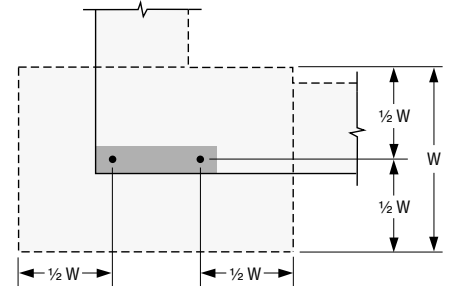

Footing Plan

SLAB-ON-GRADE INSTALLATION

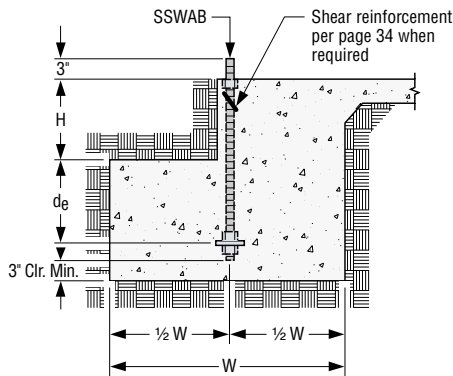

Slab-on-Grade Section View



Perspective View

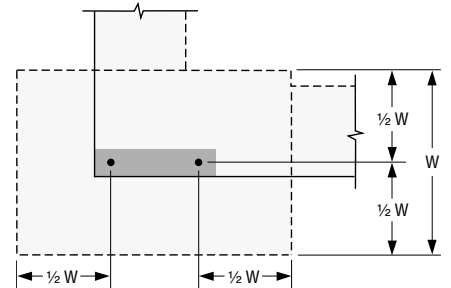

Footing Plan

BRICK LEDGE INSTALLATION

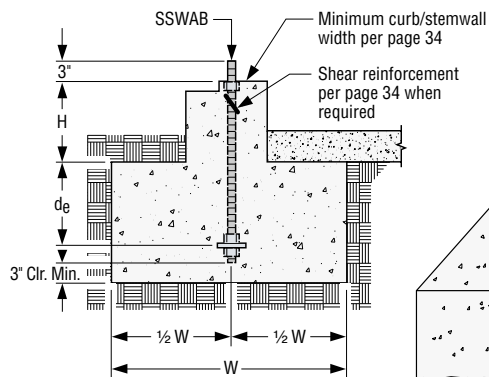

Brick Ledge Section View

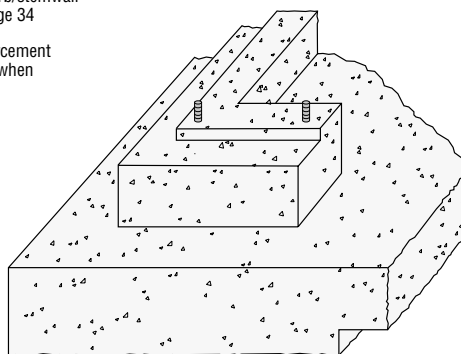

Perspective View

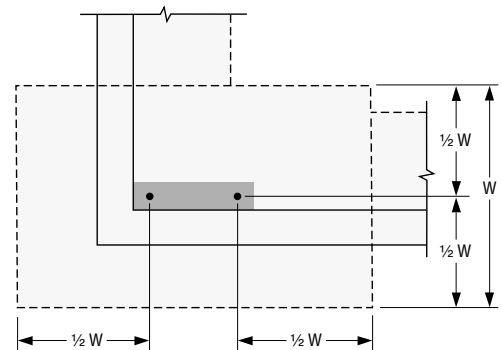

Footing Plan

Anchorage Solutions General Notes

1. The Designer may specify alternate embedment, footing size or bolt grade.
2. Footing dimensions and rebar requirements are for anchorage only.

Foundation design
(size and reinforcement) by Designer.

STEEL STRONG-WALL®: Anchorage Solutions

INTERIOR INSTALLATION

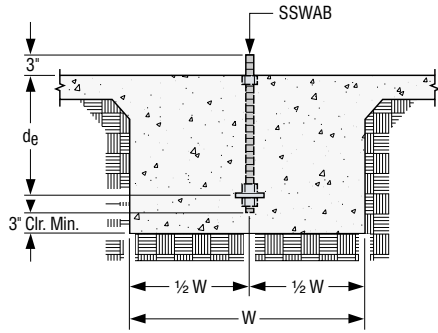

Interior Section View

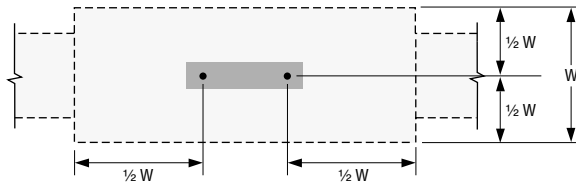

Footing Plan

STEMWALL EXTENSION INSTALLATION

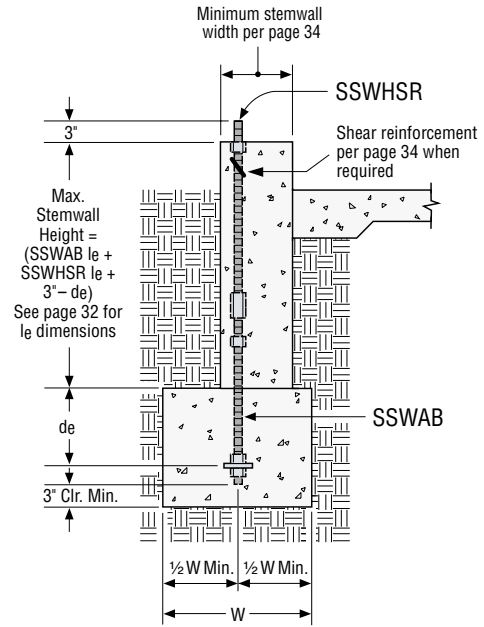

Section at Stemwall SSWAB and SSWHSR Extension Application

Anchorage Solutions General Notes

1. The Designer may specify alternate embedment, footing size or bolt grade.
2. Footing dimensions and rebar requirements are for anchorage only.

STEEL STRONG-WALL® ANCHOR BOLT LAYOUT

Wall Model	Distance From End of Wall to Center of SSWAB's (A)	Distance From Center to Center of SSWAB's (B)	Distance From Exterior Face of Wall to Center of All SSWAB's (C)
SSW12	2 ⁹ / ₁₆ "	6 ⁷ / ₈ "	2"
SSW15	2 ⁷ / ₈ "	9 ¹ / ₄ "	1 ⁷ / ₈ "
SSW18	2 ⁷ / ₈ "	12 ¹ / ₄ "	1 ⁷ / ₈ "
SSW21	2 ⁷ / ₈ "	15 ¹ / ₄ "	1 ⁷ / ₈ "
SSW24	2 ⁷ / ₈ "	18 ¹ / ₄ "	1 ⁷ / ₈ "

