

WOOD STRONG-WALL®: Standard Wall on Concrete Foundations

INSTALLATION

- Drilling or cutting holes in Wood Strong-Wall® is not allowed except as shown on pages 74-75 and the Allowable Hole Chart attached to each wall.
- For holdowns, per ASTM standards, anchor bolt nuts should be finger-tight plus 1/3 to 1/2 turn with a hand wrench, with consideration given to possible future wood shrinkage. Care should be taken to avoid over-torquing the nut, an impact wrench should not be used.
- Walls may also be used in 2x6 wall framing. Install the sheathing side at the exterior wall line and add furring to the interior framing side.

CODES: ICC-ES ESR-1267; City of L.A. RR 25427;
California DSA PA-110; State of Florida FL11177

NAMING SCHEME – 8' to 10'

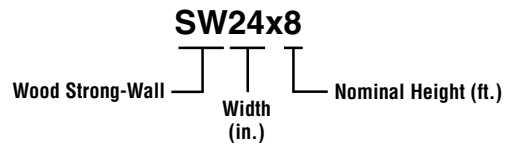

NAMING SCHEME – 12'

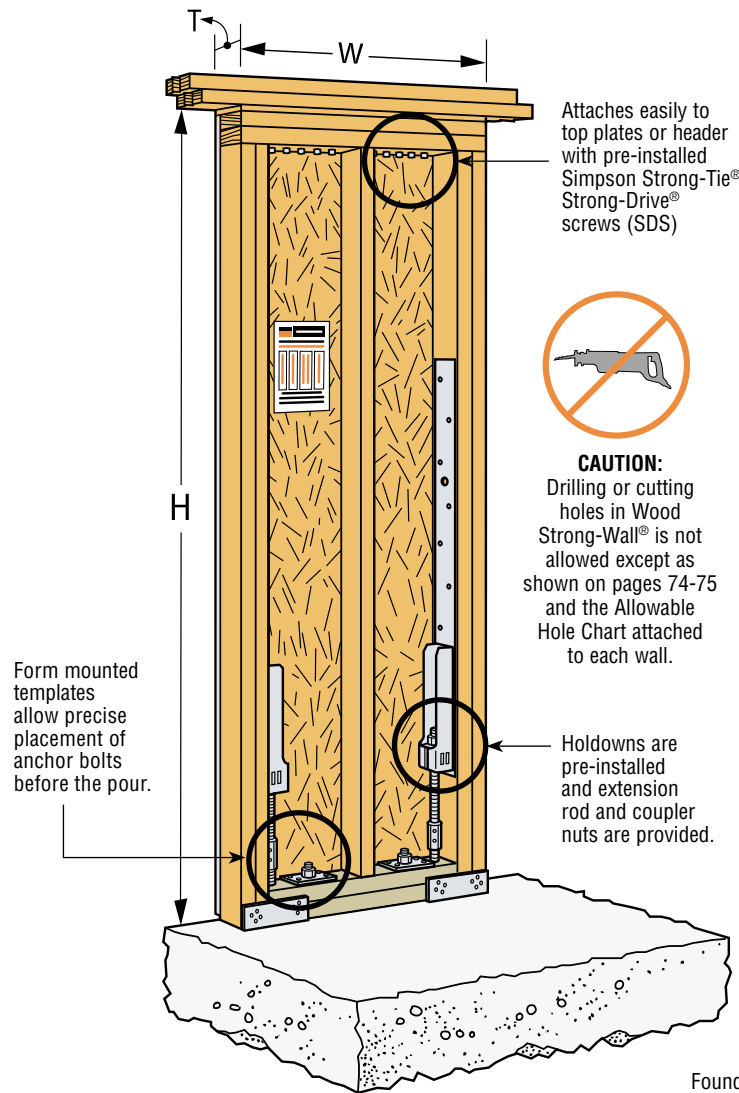
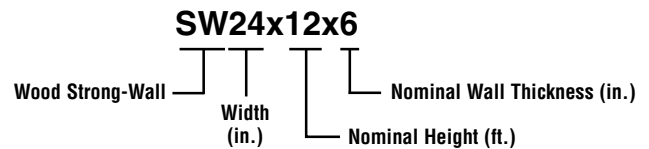

STANDARD WOOD STRONG-WALL®

U.S. Patents 5,706,626; 6,006,487,
6,109,850, 6,327,831, and 6,643,986

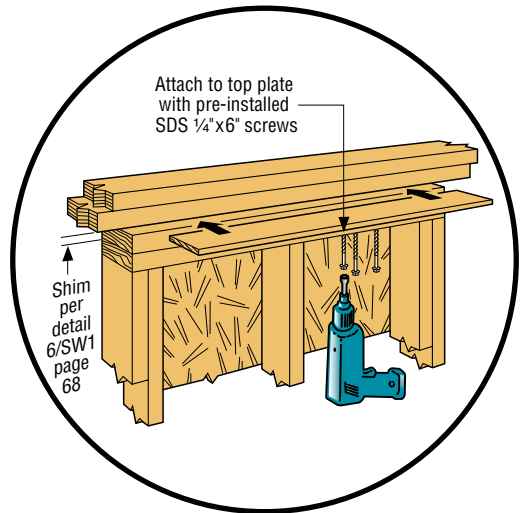

TOP-OF-WALL CONNECTION

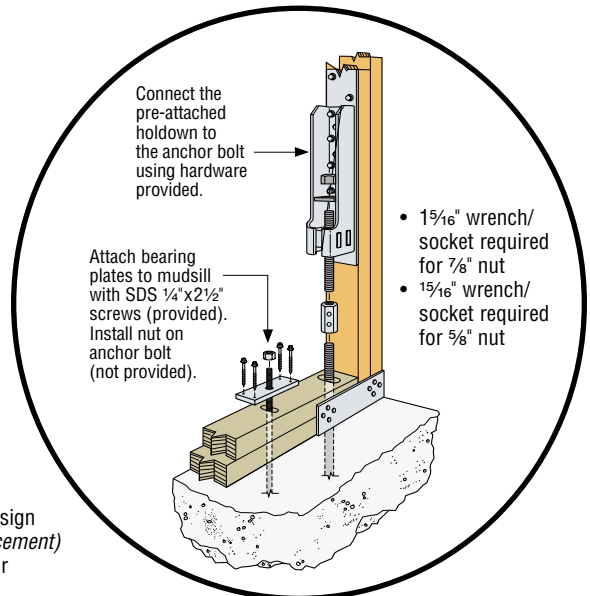

BOTTOM-OF-WALL INSTALLATION

WOOD STRONG-WALL®: Standard Wall on Concrete Foundations

STANDARD WALL PRODUCT DATA

Model No.	W (in)	H (in)	T (in)	Number of Screws in Top of Wall	Mudsill Anchors¹		Holddown² Anchor Bolts	
					Qty.	Dia.	Qty.	Model
SW18x8	18	93¼	3½	9	2	⅝"	2	SWAB⅞
SW24x8	24	93¼	3½	12	2	⅝"	2	SWAB⅞
SW32x8	32	93¼	3½	16	2	⅝"	2	SWAB⅞
SW48x8	48	93¼	3½	24	3	⅝"	2	SWAB⅞
SW18x9	18	105¼	3½	9	2	⅝"	2	SWAB⅞
SW24x9	24	105¼	3½	12	2	⅝"	2	SWAB⅞
SW32x9	32	105¼	3½	16	2	⅝"	2	SWAB⅞
SW48x9	48	105¼	3½	24	3	⅝"	2	SWAB⅞
SW24x10	24	117¼	3½	12	2	⅝"	2	SWAB⅞
SW32x10	32	117¼	3½	16	2	⅝"	2	SWAB⅞
SW48x10	48	117¼	3½	24	3	⅝"	2	SWAB⅞
SW24x12x6	24	141¼	5½	12	2	⅝"	2	SWAB⅞
SW32x12x6	32	141¼	5½	16	2	⅝"	2	SWAB⅞
SW48x12x6	48	141¼	5½	24	3	⅝"	2	SWAB⅞

1. Recommended minimum ⅝"x12" mudsill anchor.
2. Alternate ⅞" diameter anchorage may be required depending on load for two-story applications.

2006 INTERNATIONAL BUILDING CODE®

Model No.	Seismic		Wind	
	Allowable ASD Shear Load V (lbs)	Drift at Allowable Shear (in)	Allowable ASD Shear Load V (lbs)	Drift at Allowable Shear (in)
STANDARD STRONG-WALL PANEL				
SW18x8	1100	0.33	1455	0.53
SW24x8	1530	0.37	2010	0.53
SW32x8	2550	0.33	3500	0.52
SW48x8	3390	0.27	5595	0.50
SW18x9	1040	0.37	1375	0.60
SW24x9	1530	0.39	2010	0.59
SW32x9	2055	0.31	3100	0.56
SW48x9	3015	0.28	4955	0.53
SW24x10	1525	0.42	1950	0.63
SW32x10	2055	0.33	2785	0.55
SW48x10	3015	0.30	4450	0.50
SW24x12x6	1195	0.51	1585	0.80
SW32x12x6	1755	0.43	2310	0.65
SW48x12x6	2770	0.36	3690	0.53

1. For plywood shear panel, add "P" to model name (e.g. SW24x8P), and multiply the table loads by 0.88.
2. Typical shim thickness between the Strong-Wall® and top plates or header is ⅞" or less using Simpson Strong-Tie® Strong-Drive® ¼"x6" screws (SDS). For additional shim thickness, see detail 7/SW1 on page 68.
3. See allowable vertical load table on page 47 for Wood Strong-Wall maximum compression and tension capacities.
4. Standard walls may be installed with sheathing facing inside or outside.
5. Allowable shear capacities must be reduced as limited by anchor bolt capacities for installations on CMU.
6. Uplift forces may be calculated using the following formula:

$$\text{Uplift} = \frac{\text{Shear} \times \text{Height}}{\text{Width} - 5\frac{1}{4}''}$$

See page 48 for SWAB anchorage solutions.

HUSC and HUCQ: Concealed-Flange Face-Mount Hangers

When attaching door and window headers to the Wood Strong-Wall®, only the HUSC46 or HUCQ410 may be used. The fastening pattern to the carrying member is grouped in toward the center of the hanger, thereby allowing installation in end conditions.

INSTALLATION

- Nailing into the end grain of the wall's top plate to install the HUSC results in allowable loads that are 0.67 of the table load.
- Fastening into the end grain of the wall's top plate to install the HUCQ is not allowed.
- When installing the HUCQ, omit the two Simpson Strong-Tie® Strong-Drive® screws (SDS) closest to the point where the Wood Strong-Wall sheathing meets the post (see drawing on the right). Also, maintain a minimum end distance of 2" from the top of the Wood Strong-Wall post.

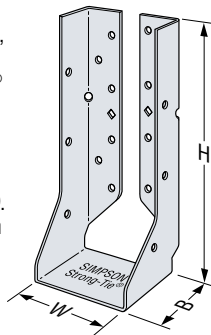

HUCQ410

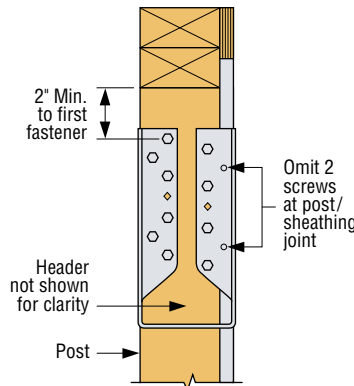

TYPICAL INSTALLATION OF HUCQ

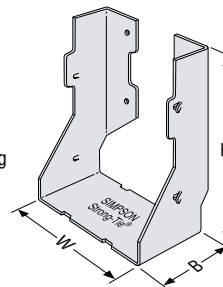

HUSC46

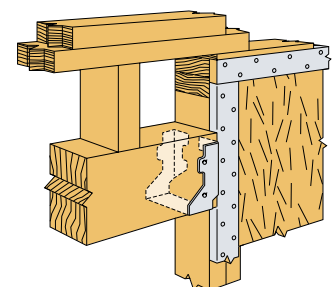

TYPICAL INSTALLATION OF HUSC46

Concealed Flange Joist Hanger Load Values Installed on Wood Strong-Wall®

Model No.	Ga	Dimensions			Fasteners		Allowable Loads (lbs)				
		W	H	B	Strong-Wall®	Header	Uplift¹		Floor	Snow	Roof
							(133)	(160)	(100)	(115)	(125)
HUSC46	14	3⅞	5	2	4-16d	4-16d	1080	1235	1005	1155	1255
HUCQ410-SDS	14	3⅞	9	3	10-SDS ¼"x2½"	6-SDS ¼"x2½"	2400	2400	3900	3940	3940

1. Uplift values based on DF/SP header material. See current Simpson Strong-Tie® Wood Construction Connectors catalog for other species.