

CONNECTOR SELECTION GUIDE



FOR USE WITH PRODUCTS
MANUFACTURED BY:



Boise Cascade
Engineered Wood Products

Boise and ALLJoist
are trademarks of
Boise Cascade, L.L.C.,
and its subsidiaries.

AJS I-JOISTS



This guide lists popular options for Simpson Strong-Tie® hangers used with engineered wood products. Not all available hanger and installation combinations are listed. Use in conjunction with the current Simpson Strong-Tie Canadian **Wood Construction Connectors** catalogue for detailed hanger information.



**LIMIT
STATES
DESIGN**

800-999-5099
www.strongtie.com

DISTRIBUTED BY:

CONNECTOR SELECTOR NOTES



General Notes

- See current Canadian *Wood Construction Connectors* catalogue for Important Information and General Notes section and for hanger models, joist sizes, and header situations not shown. See pages 10-12 for installation information.
- Unless otherwise noted, factored resistances (downloads) listed address hanger/header/fastener limitations assuming header material is Douglas Fir-Larch or Spruce Pine Fir. For LVL headers made primarily of Douglas Fir/Southern Pine, use the values found in the DF column. For LVL headers made primarily from Spruce Pine Fir or similar less dense veneers, use the values found in the SPF column. Loads are in pounds. Joist reaction should be checked by a qualified designer to ensure proper hanger selection.
- Factored uplift resistances (uplift) listed assume SPF joist and header and have been increased by 15% for earthquake and wind loading with no further increase allowed. Reduce loads according to code for normal duration loading such as cantilever construction.
- If hanger height is less than 60% of joist height, joist rotation may occur; see Prevent Rotation information below.
- Top flange hanger configuration and thickness of top flange need to be considered for flush frame conditions, see page 10.
- For this publication, carrying members are assumed to be at least 5½ inches tall. The horizontal thickness of the carrying member must be at least the length of nail being used or the hanger top flange dimension, whichever is greater.
Exception: narrower carrying members may be used with face mount hangers but the horizontal thickness must be at least 1¼ inches for 10d nails; 2 inches for 16d nails. Clinch nails on back side.
- THAI hangers in this publication are based on a "top flange" installation and require that the carrying member have a horizontal thickness of at least 2½ inches. Backer blocks are required when the header is an I-joist.
- All nails shown are common nails unless otherwise noted.
- I-joists that are used as headers require backer blocks. See Wood I-Joist Headers below for additional information.
- Multiple Members:** Multiple members should be adequately connected together to act as one unit.

Wood I-Joist Headers

I-Joist Headers: When supporting one I-joist from another, backer blocks must be used. Backer blocks are to be made from plywood, OSB, or dimension lumber. The thickness of a backer block should be the same thickness as the void in the side of the I-joist and a minimum of 12" wide. Attach with 10-10d common nails clinched as necessary, prior to installing the hanger. For Top Flange hangers, install backer blocks tight to top flange. For Face Mount hangers, install backer blocks tight to bottom flange. Refer to I-Joist manufacturer literature for specific guidelines.

Use 10d x 1½" nails for all Top Flange hangers attached to an I-joist header. See table for allowable loads.

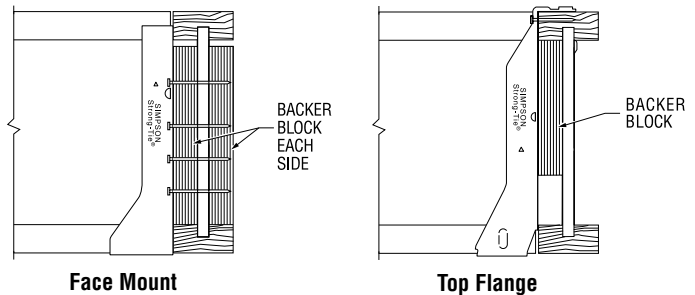

Model	I-Joist Header Flange Material ¹	
	DF/SCL	SPF
ITS	1375	1375
LT	1695	1695
MIT	1900	1900
LBV	2200	2200
BA	2420	2420

- For flanges with thicknesses from 1¾" to 1¾", use 0.85 of the I-joist header load. For flanges with thicknesses from 1½" to 1¼", use 0.75 of the I-joist header load.

Sloped Joists: For joists sloped up to ¼:12, regular (non-sloped) hangers may be used at full load value. For slopes greater than ¼:12, see adjacent table.

Sloped Joist		
Model	Slope	Reduction
All Models	up to ¼:12	no reduction
ITS, IUS, LT, LF, MIT, MIU, LBV, B, HB	up to ½:12	10%
WP, HW	up to ¾:12	15%

For face mount hangers using 10d nails with headers less than 1¾" wide horizontally but at least 1½" wide, apply a reduction factor of 0.77 to all table loads.

Prevent Rotation

Hangers provide some joist rotation resistance; however, additional lateral restraint may be required for deep joists.

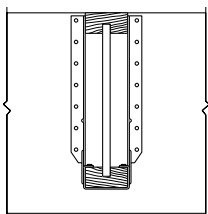

No Web Stiffener Installed
Hanger side flange supports joist top flange.

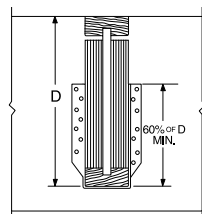

Web Stiffener Required
Hanger side flange should be at least 60% of joist depth or potential joist rotation must be addressed.

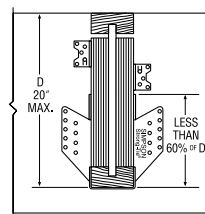

Rotation Resistance
If non-skewed hanger side flange is less than 60% of joist depth, attach staggered A34 framing anchors above the hanger.

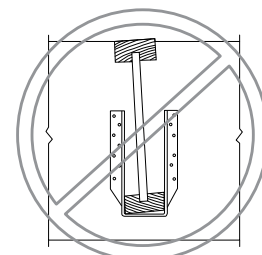

No Web Stiffener Results in Rotation
Hanger side flange is below the joist top flange. No web stiffener results in rotation, unless restrained by other means.

HOW TO PICK A HANGER

Follow these simple steps to choose your hanger:

1	Find your joist size in this guide.
2	Choose your header type. Solid header or I-joist. <ul style="list-style-type: none">• Solid headers include solid sawn Douglas Fir, Spruce-Pine Fir, and LVL.• For I-joist header see page 2.
3	Locate your connector type in the table. <ul style="list-style-type: none">• Face mount, top flange, skewed, sloped, etc.
4	Select a hanger from the table.
5	Confirm that your factored joist reaction is less than the factored resistance of hanger. If yes, you have successfully selected your hanger.
	If you did not find a suitable hanger; Please see the current Canadian <i>Wood Construction Connectors</i> catalogue or call Simpson Strong-Tie at (800) 999-5099. You will need the following information: <ul style="list-style-type: none">• Download• Uplift• Header condition• Bearing length requirement

SINGLE I-JOISTS – Canadian/Factored Resistance (lbs)



Joist Height	Top Flange						Snap-In						Face Mount																								
	Model	B Dim	Fastener Type		Uplift (115)	Down Load	Model	B Dim	Fastener Type		Uplift (115)	Down Load	Model	B Dim	Fastener Type		Uplift (115)	Down Load																			
			Header	Joist					Header	Joist					Header	Joist			Header	Joist																	
AJS 140, 20																			Joist Width = 2 1/2"																		
9 1/2	LT259	2	6-10d	1-#8x1 1/4WS	100	2560	1725	IUS2.56/9.5	2	8-10d	—	105	2385	1700	LF259	2	10-10d	1-#8x1 1/4WS	100	2525	2155																
11 1/8	LT251188	2	6-10d	1-#8x1 1/4WS	100	2560	1725	IUS2.56/11.88	2	10-10d	—	105	2565	1835	LF2511	2	12-10d	1-#8x1 1/4WS	100	2880	2270																
14	LT2514	2	6-10d	1-#8x1 1/4WS	100	2560	1725	IUS2.56/14	2	12-10d	—	105	2565	1835	LF2514	2	14-10d	1-#8x1 1/4WS	100	3235	2385																
16	LT2516	2	6-10d	1-#8x1 1/4WS	100	2560	1725	IUS2.56/16	2	14-10d	—	105	2725	1950	MIU2.56/16	2 1/2	24-16d	2-10dx1 1/2	270	4930	3485																
AJS 25																			Joist Width = 3 1/2"																		
9 1/2	LT359	2	6-10d	2-#8x1 1/4WS	100	2560	1725	IUS3.56/9.5	2	10-10d	—	105	2375	1695	LF359	2	10-10d	2-#8x1 1/4WS	100	2525	2155																
11 1/8	LT351188	2	6-10d	2-#8x1 1/4WS	100	2560	1725	IUS3.56/11.88	2	12-10d	—	105	2375	1695	LF3511	2	12-10d	2-#8x1 1/4WS	100	2880	2270																
14	LT3514	2	6-10d	2-#8x1 1/4WS	100	2560	1725	IUS3.56/14	2	12-10d	—	105	2375	1695	LF3514	2	14-10d	2-#8x1 1/4WS	100	3235	2385																
16	LT3516	2	6-10d	2-#8x1 1/4WS	100	2560	1725	IUS3.56/16	2	14-10d	—	105	2375	1695	MIU3.56/16	2 1/2	24-16d	2-10dx1 1/2	270	4930	3485																
18	MIT418	2 1/2	8-16d	2-10dx1 1/2	380	3480	2415	No IUS Hanger for these sizes						MIU3.56/18	2 1/2	26-16d	2-10dx1 1/2	270	4930	3485																	

1. Shaded hangers require web stiffeners at joist ends. Web stiffeners may be required for non-shaded hangers by others.
2. THAI hangers require a minimum of 4 top and 2 face nails installed.
3. The B Dim is the depth of the hanger seat.
4. WS = wood screw

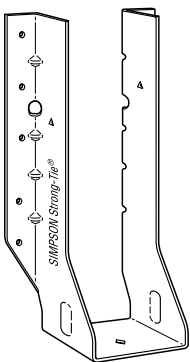

LF

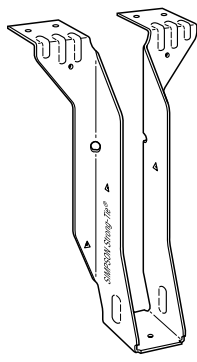

LT

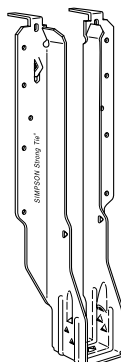

IUS

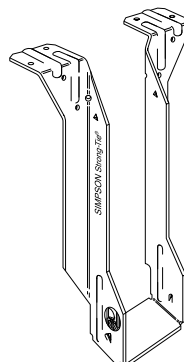

MIT

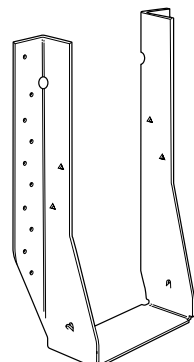

MIU

LF – 18 gauge
LT – 18 gauge
 The LF and LT series feature fast and easy installation. No web stiffeners required and only one screw secures joist in hanger.

IUS – 18 gauge
 The IUS is a new hybrid hanger that incorporates the advantages of face-mount and top-flange hangers. Joist nails are not required.

MIT – 16 gauge
 The MIT's Positive Angle Nailing helps minimize splitting of the I-joists' bottom flange. Features uplift capacity and extended seat design (to allow installation of slightly undercut joists).

MIU – 16 gauge
 The MIU series features 16 gauge steel and extra nailing for higher loads than the LF.

SINGLE I-JOISTS – Canadian/Factored Resistance (lbs)



Joist Height	45° Skew							Adjustable Height						Field Slope & Skew							
	Model	B Dim	Fastener Type		Uplift (115)	Down Load		Model	B Dim	Fastener Type		Uplift (115)	Down Load		Model	B Dim	Fastener Type		Uplift (115)	Down Load	
			Header	Joist		DF	SPF			Header	Joist		DF	SPF			Header	Joist		DF	SPF
AJS 140, 20																					
Joist Width = 2½"																					
9½	SUR/L2.56/9	3⅞	14-16d	2-10dx1½	385	3945	2780	THAI322	2¼	6-10d	2-10dx1½	—	2740	2075	LSSUH310	3½	14-16d	12-10dx1½	1220	2620	1850
11⅞	SUR/L2.56/11	3⅞	16-16d	2-10dx1½	385	3945	2780	THAI322	2¼	6-10d	2-10dx1½	—	2740	2075	LSSUH310	3½	14-16d	12-10dx1½	1220	2620	1850
14	SUR/L2.56/14	3⅞	18-16d	2-10dx1½	385	3945	2780	THAI322	2¼	6-10d	2-10dx1½	—	2740	2075	LSSUH310	3½	14-16d	12-10dx1½	1220	2620	1850
16	SUR/L2.56/14	3⅞	18-16d	2-10dx1½	385	3945	2780	See Canadian <i>Wood Construction Connectors Catalogue</i> for hanger selection.						See Canadian <i>Wood Construction Connectors Catalogue</i> for hanger selection.							
AJS 25																					
Joist Width = 3½"																					
9½	SUR/L410	2⅝	14-16d	6-16d	1395	4065	2875	THAI422	2¼	6-10d	2-10dx1½	—	2740	2075	LSSU410	3½	14-16d	12-10dx1½	1220	3055	2160
11⅞	SUR/L410	2⅝	14-16d	6-16d	1395	4065	2875	THAI422	2¼	6-10d	2-10dx1½	—	2740	2075	LSSU410	3½	14-16d	12-10dx1½	1220	3055	2160
14	SUR/L414	2½	18-16d	8-16d	1555	4095	2895	THAI422	2¼	6-10d	2-10dx1½	—	2740	2075	LSSU410	3½	14-16d	12-10dx1½	1220	3055	2160
16	SUR/L414	2½	18-16d	8-16d	1555	4095	2895	See Canadian <i>Wood Construction Connectors Catalogue</i> for hanger selection.						See Canadian <i>Wood Construction Connectors Catalogue</i> for hanger selection.							
18	SUR/L414	2½	18-16d	8-16d	1555	4095	2895	See Canadian <i>Wood Construction Connectors Catalogue</i> for hanger selection.						See Canadian <i>Wood Construction Connectors Catalogue</i> for hanger selection.							

1. See notes on page 4.

Specified Nail	CSA 086-01 Nail
8d	2½" common wire
10d	3" common wire
16d	3½" common wire

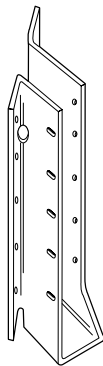

SUL

SUR/L, SUR/L1 – 16 gauge
HSUR/L – 14 gauge
 All models are skewed 45°. Normally accommodates a 40° - 50° skew. The installation of these hangers does not require a beveled end cut.

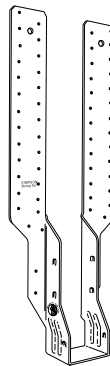

THAI

THAI – 18 gauge
 This hanger has extra long straps and can be field-formed to give height adjustability and top flange hanger convenience. Positive angle nailing helps minimize splitting of the I-joist's bottom flange. Minimum nailing is shown in the table above. Strap must be field-formed over the top of the header by a minimum of 2½". Web stiffeners required when used with I-joists.

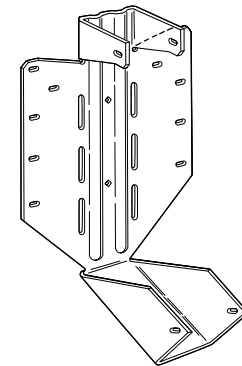

LSSU

LSSU, LSSUI – 18 gauge
LSSU210-2, LSSU410, and LSSUH310 – 16 gauge
LSU – 14 gauge
 LSSU models provide uplift capacity and can be field sloped and/or skewed to 45°. Web stiffeners required when used with I-joists; cut web stiffener to match angle on sloped conditions.

DOUBLE I-JOISTS – Canadian/Factored Resistance (lbs)



Joist Height	Top Flange						Face Mount						45° Skew											
	Model	B Dim	Fastener Type		Uplift (115)	Down Load			Model	B Dim	Fastener Type		Uplift (115)	Down Load			Model	B Dim	Fastener Type		Uplift (115)	Down Load		
			Header	Joist		DF	SPF	Header			Joist	DF		SPF	Header	Joist			DF	SPF				
Double AJS 140, 20																								
Joist Width = 5"																								
9½	MIT39.5-2	2½	8-16d	2-10dx1½	380	3480	2415	MIU5.12/9	2½	16-16d	2-10dx1½	270	4550	3215	HSUR/L5.12/9	2¼ ³ / ₁₆	12-16d	2-10dx1½	195	2995	2350			
11¾	MIT311.88-2	2½	8-16d	2-10dx1½	380	3480	2415	MIU5.12/11	2½	20-16d	2-10dx1½	270	4550	3215	HSUR/L5.12/11	2¼ ³ / ₁₆	16-16d	2-10dx1½	195	4195	2965			
14	MIT314-2	2½	8-16d	2-10dx1½	380	3480	2415	MIU5.12/14	2½	22-16d	2-10dx1½	270	4930	3485	HSUR/L5.12/14	2¼ ³ / ₁₆	20-16d	2-10dx1½	195	4195	2965			
16	MIT5.12/16	2½	8-16d	2-10dx1½	380	3480	2415	MIU5.12/16	2½	24-16d	2-10dx1½	270	4930	3485	HSUR/L5.12/16	2¼ ³ / ₁₆	24-16d	2-10dx1½	195	4195	2965			
Double AJS 25																								
Joist Width = 7"																								
9½	B7.12/9.5	2½	14-16d	6-16d	1170	5940	3910	HU410-2	2½	18-16d	8-16d	1865	5780	4670	HU410-2X ⁴	2½	18-16d	8-16d	1400	3755	3035			
11¾	B7.12/11.88	2½	14-16d	6-16d	1170	5940	3910	HU412-2	2½	22-16d	8-16d	1865	5780	4670	HU412-2X ⁴	2½	22-16d	8-16d	1400	3755	3035			
14	B7.12/14	2½	14-16d	6-16d	1170	5940	3910	HU414-2	2½	26-16d	12-16d	2685	7025	5780	HU414-2X ⁴	2½	26-16d	12-16d	2015	4565	3755			
16	B7.12/16	2½	14-16d	6-16d	1170	5940	3910	HU414-2	2½	26-16d	12-16d	2685	7025	5780	HU414-2X ⁴	2½	26-16d	12-16d	2015	4565	3755			
18	B7.12/18	2½	14-16d	6-16d	1170	5940	3910	HU414-2	2½	26-16d	12-16d	2685	7025	5780	HU414-2X ⁴	2½	26-16d	12-16d	2015	4565	3755			

1. Shaded hangers require web stiffeners at joist ends. Web stiffeners may be required for non-shaded hangers by others.
2. THAI hangers require a minimum of 4 top and 2 face nails installed. THAI-2 must be special ordered, specify hanger seat width between 3⅞" and 5⅞"
3. LSU5.12 skew options must be factory ordered.
4. Skewed option must be special ordered. Specify skew angle and direction (i.e. HU410-2X, SKR 45°).
5. The B Dim is the depth of the hanger seat.

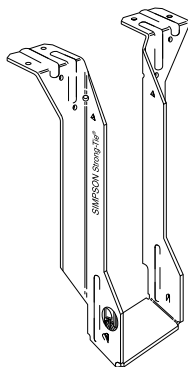

MIT

MIT – 16 gauge
The MIT's Positive Angle Nailing helps minimize splitting of the I-joists' bottom flange. Features uplift capacity and extended seat design (to allow installation of slightly undercut joists).

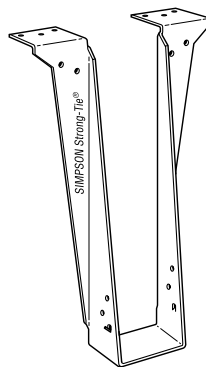

LBV

LBV – 14 gauge
The LBV is designed especially for use with multiple ply headers 1½" to 1¾" thick, and may be used for weld-on applications.

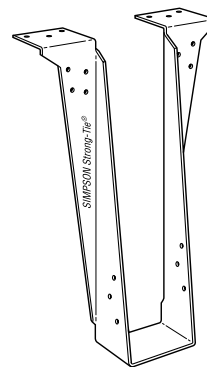

B

B – 12 gauge
The B series offers versatility for I-joists and SCL lumber. Enhanced load capacity widens the range of applications for these hangers.

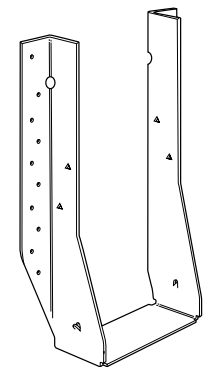

MIU

MIU – 16 gauge
The MIU series features 16 gauge steel and extra nailing for higher loads than the LF.

DOUBLE I-JOISTS – Canadian/Factored Resistance (lbs)



Joist Height	Adjustable Height						Field Slope & Skew								
	Model	B Dim	Fastener Type		Uplift (115)	Down Load		Model	B Dim	Fastener Type		Uplift (115)	Down Load		
			Header	Joist		DF	SPF			Header	Joist		DF	SPF	
Double AJS 140, 20												Joist Width = 5"			
9½	THAI-2 ²	2½	6-10d	2-10dx1½	—	2935	2935	LSU5.12 ³	3½	24-16d	16-10dx1½	910	2600	1835	
11¾	THAI-2 ²	2½	6-10d	2-10dx1½	—	2935	2935	LSU5.12 ³	3½	24-16d	16-10dx1½	910	2600	1835	
14	THAI-2 ²	2½	6-10d	2-10dx1½	—	2935	2935	LSU5.12 ³	3½	24-16d	16-10dx1½	910	2600	1835	
16	See Canadian <i>Wood Construction Connectors</i> Catalogue for hanger selection.						See Canadian <i>Wood Construction Connectors</i> Catalogue for hanger selection.								
Double AJS 25												Joist Width = 7"			
9½	See Canadian <i>Wood Construction Connectors</i> Catalogue for hanger selection.						See Canadian <i>Wood Construction Connectors</i> Catalogue for hanger selection.								
11¾															
14															
16															
18															

1. See notes on page 6.

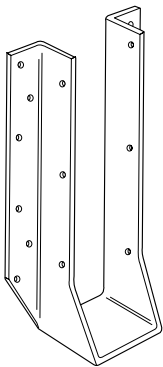

HU

HU – 14 gauge
The HU series features uplift capacity and a large selection of sizes and load ranges. HU hangers have triangle holes that can be filled for increased loads. Web stiffeners required when used with I-joists.

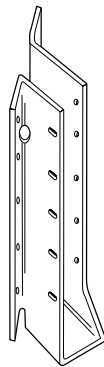

SUL

SUR/L – 16 gauge
HSUR/L – 14 gauge
All models are skewed 45°. Normally accommodates a 40°- 50° skew. The installation of these hangers does not require a beveled end cut.

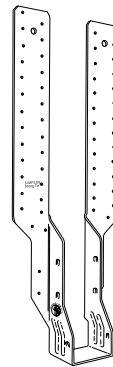

THAI

THAI – 18 gauge
THAI-2 – 14 gauge
This hanger has extra long straps and can be field-formed to give height adjustability and top flange hanger convenience. Positive angle nailing helps minimize splitting of the I-joist's bottom flange. Minimum nailing is shown in the table above. Strap must be field-formed over the top of the header by a minimum of 2½". Web stiffeners required when used with I-joists.

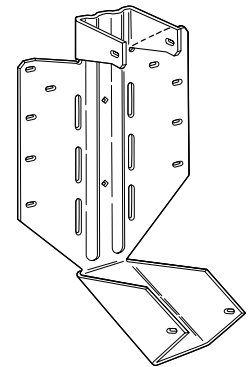

LSSU

LSSU/LSSUI – 18 gauge
LSSU210-2, LSSU410 – 16 gauge
LSU – 14 gauge
LSSU models provide uplift capacity and can be field sloped and/or skewed to 45°. Web stiffeners required when used with I-joists.

BEAMS and HEADERS – Canadian/Factored Resistance (lbs)



Joist Height	Top Flange							Face Mount						
	Model	B Dim	Fastener Type		Uplift (115)	Normal		Model	B Dim	Fastener Type		Uplift (115)	Normal	
			Header	Joist		DF	SPF			Header	Joist		DF	SPF
1 3/4" Versa-Lam LVL														
7 1/4	LBV1.81/7.25	3	10-16d	2-10dx1 1/2	435	3905	3125	HU7	2 1/2	16-16d	8-10dx1 1/2	2175	5445	4040
9 1/4	LBV1.81/9.25	3	10-16d	2-10dx1 1/2	435	3905	3125	HU7	2 1/2	16-16d	8-10dx1 1/2	2175	5445	4040
	WPU1.81/9.25	4	7-16d	6-10dx1 1/2	1085	6390	6390	HUS1.81/10	3	30-16d	10-16d	5480	7130	5255
9 1/2	MIT9.5	2 1/2	8-16d	2-10dx1 1/2	535	3480	2415	HU9	2 1/2	24-16d	10-10dx1 1/2	2715	5780	4380
	LBV1.81/9.5	3	10-16d	2-10dx1 1/2	435	3905	3125	HUS1.81/10	3	30-16d	10-16d	5480	7130	5255
11 1/4	LBV1.81/11.25	3	10-16d	2-10dx1 1/2	435	3905	3125	HU11	2 1/2	30-16d	10-10dx1 1/2	2715	5780	4380
	WPU1.81/11.25	4	7-16d	6-10dx1 1/2	1085	6390	6390	HUS1.81/10	3	30-16d	10-16d	5480	7130	5255
11 7/8	MIT11.88	2 1/2	8-16d	2-10dx1 1/2	535	3480	2415	HU11	2 1/2	30-16d	10-10dx1 1/2	2715	5780	4380
	BA1.81/11.88	3	16-16d	8-10dx1 1/2	1915	5940	4370	HUS1.81/10	3	30-16d	10-16d	5480	7130	5255
14	MIT1.81/14	2 1/2	8-16d	2-10dx1 1/2	535	3480	2415	HU14	2 1/2	36-16d	14-10dx1 1/2	3800	5780	5055
	LBV1.81/14	3	10-16d	2-10dx1 1/2	435	3905	3125	HUS1.81/10	3	30-16d	10-16d	5480	7130	5255
2 Ply 1 3/4" Versa-Lam LVL or 3 1/2" Versa-Lam LVL														
7 1/4	LBV3.56/7.25	2 1/2	10-16d	2-10dx1 1/2	435	3905	3125	HHUS48	3	22-16d	8-16d	3765	8945	6320
9 1/4	LBV3.56/9.25	2 1/2	10-16d	2-10dx1 1/2	435	3905	3125	HHUS410	3	30-16d	10-16d	5480	9860	6970
	HB3.56/9.25	3 1/2	22-16d	10-16d	3300	9335	5945	HGUS410	4	46-16d	16-16d	6840	14645	10355
9 1/2	LBV3.56/9.5	2 1/2	10-16d	2-10dx1 1/2	435	3905	3125	HHUS410	3	30-16d	10-16d	5480	9860	6970
	HB3.56/9.5	3 1/2	22-16d	10-16d	3300	9335	5945	HGUS410	4	46-16d	16-16d	6840	14645	10355
11 1/4	LBV3.56/11.25	2 1/2	10-16d	2-10dx1 1/2	435	3905	3125	HHUS410	3	30-16d	10-16d	5480	9860	6970
	HB3.56/11.25	3 1/2	22-16d	10-16d	3300	9335	5945	HGUS412	4	56-16d	20-16d	7640	14995	10595
11 7/8	BA3.56/11.88	3	16-16d	8-10dx1 1/2	1915	5940	4370	HHUS410	3	30-16d	10-16d	5480	9860	6970
	HB3.56/11.88	3 1/2	22-16d	10-16d	3300	9335	5945	HGUS412	4	56-16d	20-16d	7640	14995	10595
14	BA3.56/14	3	16-16d	8-10dx1 1/2	1915	5940	4370	HHUS410	3	30-16d	10-16d	5480	9860	6970
	SCL3.62/14	4	6-16d	6-16d	1980	13395	6775	HGUS414	4	66-16d	22-16d	10130	16400	11595
16	BA3.56/16	3	16-16d	8-10dx1 1/2	1915	5940	4370	HGUS414	4	66-16d	22-16d	10130	16400	11595
	SCL3.62/16	4	6-16d	6-16d	1980	13395	6775	HGUS414	4	66-16d	22-16d	10130	16400	11595
18	HB3.56/18	3 1/2	22-16d	10-16d	3300	9335	5945	HGUS414	4	66-16d	22-16d	10130	16400	11595
	SCL3.62/18	5	12-16d	12-16d	3960	17600	11490	HGUS414	4	66-16d	22-16d	10130	16400	11595

1. Normal load column for top flange hangers represents floor loads (100%) and may not be increased for other load durations.
2. HU hangers use both round and triangle holes.
3. When ordering HGU or HHGU specify height.
4. The B Dim is the depth of the hanger seat.

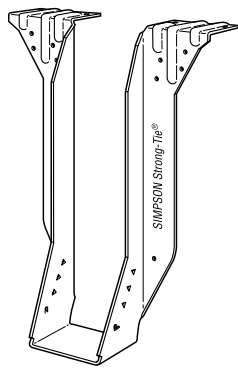

BA

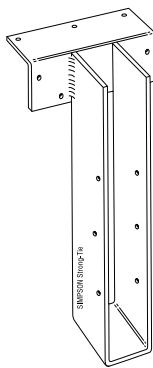

WPU

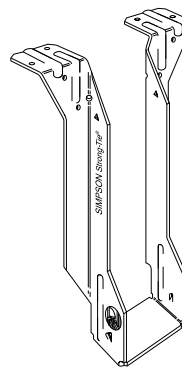

MIT

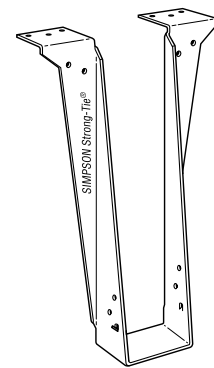

LBV

BA – 14 gauge
The BA series offers versatility for I-joists and SCL lumber. Enhanced load capacity widens the range of applications for these hangers.

W, WI – Top flange – 12 gauge; Stirrup – 12 gauge
WP, WPI, WPU – Top flange – 7 gauge; Stirrup – 12 gauge
HWU – Top flange – 3 gauge; Stirup – 10 gauge
This welded series offers the greatest design flexibility and versatility, and a large selection of sizes. Suitable for welded and nailer applications, and modifications including slopes and skews.

MIT – 16 gauge
The MIT's Positive Angle Nailing helps minimize splitting of the I-joists' bottom flange. Features uplift capacity and extended seat design (to allow installation of slightly undercut joists).

LBV – 14 gauge
The LBV is designed especially for use with multiple ply headers 1 1/2" to 1 3/4" thick, and may be used for weld-on applications.

BEAMS and HEADERS – Canadian/Factored Resistance (lbs)



Joist Height	Top Flange								Face Mount						
	Model	B Dim	Fastener Type		Uplift (115)	Normal		Model	B Dim	Fastener Type		Uplift (115)	Normal		
			Header	Joist		DF	SPF			Header	Joist		DF	SPF	
3 Ply 1 3/4" Versa-Lam LVL or 5 1/4" Versa-Lam LVL															
7 1/4	HB5.50/7.25	3 1/2	22-16d	10-16d	3300	9335	5945	HGUS5.50/8	4	36-16d	12-16d	6070	12980	9175	
9 1/4	HB5.50/9.25	3 1/2	22-16d	10-16d	3300	9335	5945	HHUS5.50/10	3	30-16d	10-16d	5480	9860	6970	
	GLTV5.50/9.25	5	10-16d	6-16d	1980	10455	7470	HGUS5.50/10	4	46-16d	16-16d	6840	14645	10355	
9 1/2	HB5.50/9.5	3 1/2	22-16d	10-16d	3300	9335	5945	HHUS5.50/10	3	30-16d	10-16d	5480	9860	6970	
	SCL5.37/9.5	4	6-16d	6-16d	1980	13395	6775	HGUS5.50/10	4	46-16d	16-16d	6840	14645	10355	
11 1/4	HB5.50/11.25	3 1/2	22-16d	10-16d	3300	9335	5945	HHUS5.50/10	3	30-16d	10-16d	5480	9860	6970	
	GLTV5.50/11.25	5	10-16d	6-16d	1980	10455	7470	HGUS5.50/12	4	56-16d	20-16d	7640	14995	10595	
11 1/8	HB5.50/11.88	3 1/2	22-16d	10-16d	3300	9335	5945	HHUS5.50/10	3	30-16d	10-16d	5480	9860	6970	
	SCL5.37/11.88	5	12-16d	12-16d	1980	17600	11490	HGUS5.50/12	4	56-16d	20-16d	7640	14995	10595	
14	HB5.50/14	3 1/2	22-16d	10-16d	3300	9335	5945	HHUS5.50/10	3	30-16d	10-16d	5480	9860	6970	
	SCL5.37/14	5	12-16d	12-16d	1980	17600	11490	HGUS5.50/14	4	66-16d	22-16d	10130	16400	11595	
16	HGLTV5.516	6	18-16d	6-16d	1980	13070	9830	HGUS5.50/14	4	66-16d	22-16d	10130	16400	11595	
	SCL5.37/16	6	10-16d	12-16d	3300	23680	13025	HGU5.50-SDS ³	5 1/4	36-SDS 1/4x2 1/2	24-SDS 1/4x2 1/2	10490	20320	18020	
18	SCL5.37/18	6	10-16d	12-16d	3300	23680	13025	HGUS5.50/14	4	66-16d	22-16d	10130	16400	11595	
								HGU5.50-SDS ³	5 1/4	36-SDS 1/4x2 1/2	24-SDS 1/4x2 1/2	10490	20320	18020	
4 Ply 1 3/4" Versa-Lam LVL or 7" Versa-Lam LVL															
9 1/4	HB7.12/9.25	3 1/2	22-16d	10-16d	3300	9335	5945	HHUS7.25/10	3 5/16	30-16d	10-16d	5480	10780	7620	
	GLTV49.25-2	5	10-16d	6-16d	1980	10455	7470	HGUS7.25/10	4	46-16d	16-16d	6840	15760	11140	
9 1/2	HB7.12/9.5	3 1/2	22-16d	10-16d	3300	9335	5945	HHUS7.25/10	3 5/16	30-16d	10-16d	5480	10780	7620	
	SCL7.25/9.5	4	6-16d	6-16d	1980	13395	6775	HGUS7.25/10	4	46-16d	16-16d	6840	15760	11140	
11 1/4	GLTV411.25-2	5	10-16d	6-16d	1980	10455	7470	HHUS7.25/10	3 5/16	30-16d	10-16d	5480	10780	7620	
	HGLTV411.25-2	6	18-16d	6-16d	1980	13070	9830	HGUS7.25/12	4	56-16d	20-16d	7640	16110	11385	
11 1/8	GLTV411.88-2	5	10-16d	6-16d	1980	10455	7470	HHUS7.25/10	3 5/16	30-16d	10-16d	5480	10780	7620	
	SCL7.25/11.88	5	12-16d	12-16d	1980	17600	11490	HGUS7.25/12	4	56-16d	20-16d	7640	16110	11385	
14	SCL7.25/14	5	12-16d	12-16d	1980	17600	11490	HGUS7.25/14	4	66-16d	22-16d	10130	18200	12865	
								HGU7.25-SDS ³	5 1/4	36-SDS 1/4x2 1/2	24-SDS 1/4x2 1/2	10490	20320	18020	
16	SCL7.25/16	6	10-16d	12-16d	3300	23680	13025	HGUS7.25/14	4	66-16d	22-16d	10130	18200	12865	
								HHGU7.25-SDS ³	5 1/4	44-SDS 1/4x2 1/2	28-SDS 1/4x2 1/2	13075	26665	23465	
18	SCL7.25/18	6	10-16d	12-16d	3300	23680	13025	HGUS7.25/14	4	66-16d	22-16d	10130	18200	12865	
								HHGU7.25-SDS ³	5 1/4	44-SDS 1/4x2 1/2	28-SDS 1/4x2 1/2	13075	26665	23465	

1. See notes on page 8.

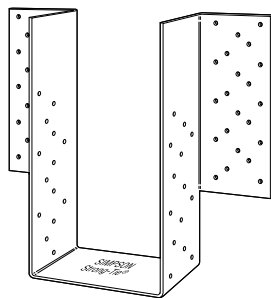

HHGU

HGU – 7 gauge
HHGU – 3 gauge
 The GU hangers are a high-capacity girder hanger designed for situations where the header and joist are flush at top.

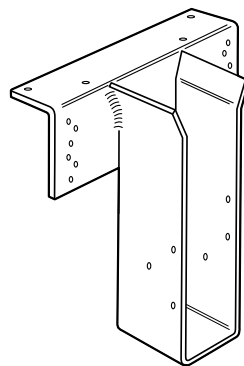

GLTV

GLTV & HGLTV – Top flange – 3 gauge
 Stirrup – 7 gauge
 This welded series provides high load carrying capacity and design flexibility and versatility. May be sloped, skewed and modified in other ways, and may be welded to steel I-beams. The GLTV may be used on 4x nailers.

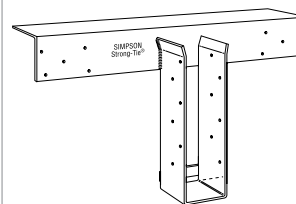

SCL

SCL – Top flange – 1/4 or 3/8 hot rolled angle
 Stirrup – 3 gauge
 This series offers high load capacities. The large top flange distributes the load to the carrying member.

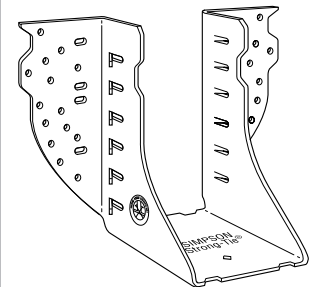

HGUS

HGUS – 12 gauge
HHUS – 14 gauge
 Features double shear nailing for high strength and lowest installed cost due to the reduced nail quantity requirement. Not suitable for use with I-joists.

Top Flange Hangers

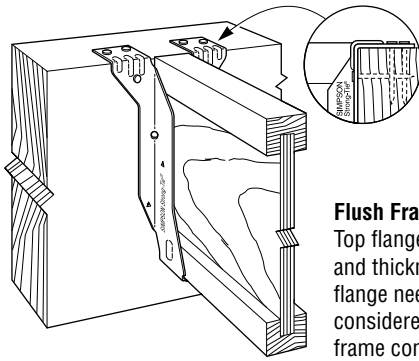

Flush Framing
Top flange configuration and thickness of top flange need to be considered for flush frame conditions.

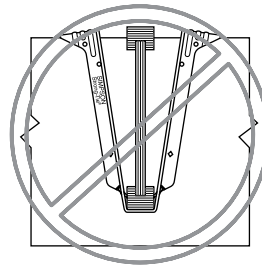

Hanger Over-Spread
If the hanger is over-spread, it can raise the I-Joist above the header and may cause uneven surfaces and squeaky floors.

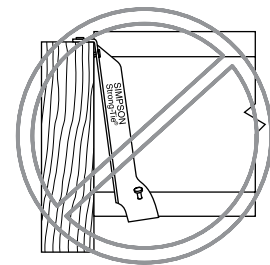

Hanger Not Plumb
A hanger "kicked out" from the header can cause uneven surfaces and squeaky floors.

Wood Nailers

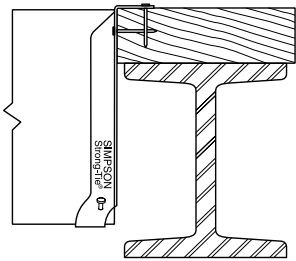

Correct Attachment

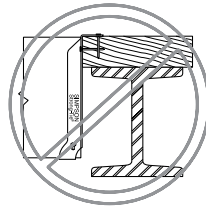

Nailer Too Wide
The loading may cause cross-grain bending. As a general rule, the maximum allowable overhang is 1/4", depending on nailer thickness.

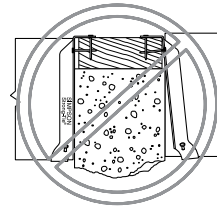

Nailer Too Narrow
A maximum mismatch of 1/8" for normal installations is acceptable.

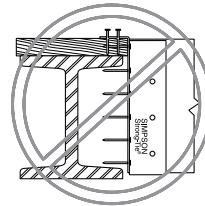

Nailer Too Thin and the wrong hanger for a nailer application.

Nail Hole Shapes

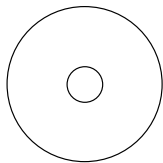

Round Holes
All holes must be filled except for the THAI adjustable height hanger. Refer to load tables for THAI nail quantities.

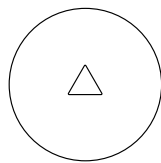

Triangle Holes
Provided on some products in addition to round holes. Round and triangle holes must be filled to achieve the published maximum load value.

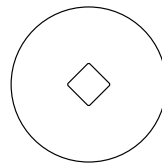

Diamond Holes
Optional holes to temporarily secure connectors to the member during installation.

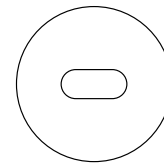

Obround Holes
Used to provide easier nailing access in tight locations. All holes must be filled except for the LSSU hanger when skewed. Refer to load tables for LSSU nail quantities.

Toe Nailed I-Joist

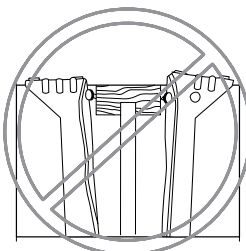

Toe nailing causes squeaks and improper hanger installations. **Do not toe nail I-joists prior to installing either top flange or face mount hangers.**

Double Shear Nailing

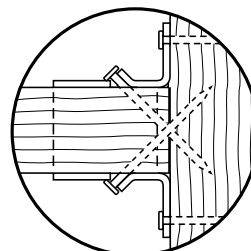

The nail is installed into joist and header, distributing load through two points on each nail for greater strength.

GENERAL CONNECTOR INSTALLATION

IUS Installation Sequence

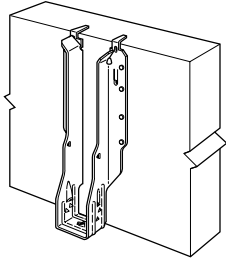

STEP 1
Attach the IUS to the header

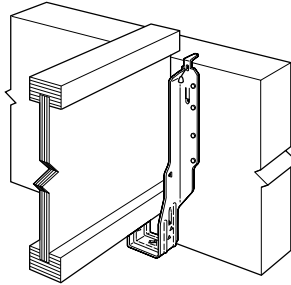

STEP 2
Slide the I-joint into the IUS until it rests above the large teardrop.

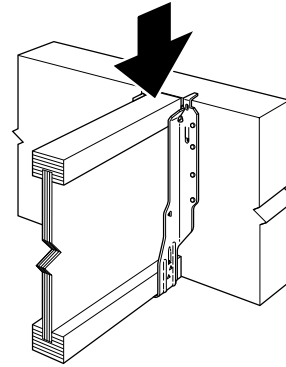

STEP 3
Firmly push or snap I-joint fully into the seat of the IUS.

LT and LF Screw Installation

Use 8 gauge (0.164" diameter) x 1 1/4" wood screw (#8x1 1/4") to secure joist to hanger.

To avoid stripping of the bottom chord screw hole, DO NOT over tighten screw.

Use specified screw to seat joist into hanger (required only for LF and LT hangers).

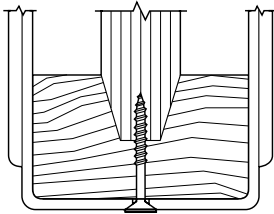

Alternate Uplift Option for IUS

This installation works for I-joists with 1 5/16" or greater depth of bottom flange. Install Simpson's SD8x1.25 tapping screw through the diamond hole in the bottom of the seat.

Model No.	Joist Fasteners	Uplift	
		DF (115)	SPF (115)
IUS	Simpson SD8x1.25 Tapping Screw ¹	250	215

- Any #8x1.25 self-drilling screw may be used.
- Loads are in pounds.

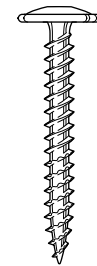

SD8x1.25
(Actual Size)

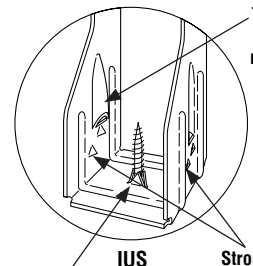

Starburst detail allows secure seating of joist.

Snap-In Teardrop No nails required!

Strong-Grip™ holds bottom chord in position

VPA Installation

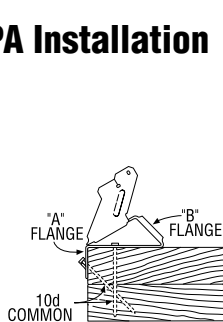

STEP 1
Install top nails and face PAN nails in "A" flange to outside wall top plate.

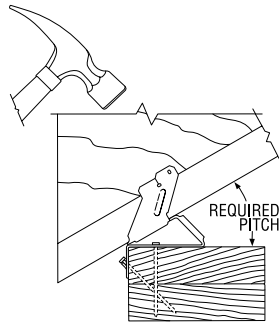

STEP 2
Seat rafter with a hammer, adjusting "B" flange to the required pitch.

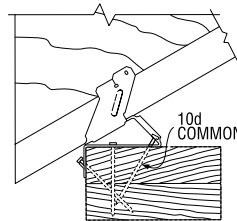

STEP 3
Install "B" flange nails in the obround nail holes, locking the pitch.

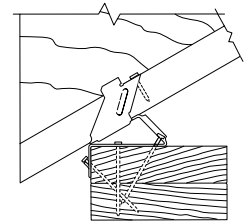

STEP 4
Bend tab with hammer and install nail into tab nail hole. Hammer nail in at approx. 45° angle to limit splitting.

LSSU Installation

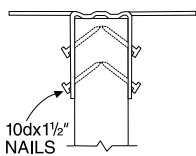

1. Nail hanger to slope-cut joist, installing seat nail first. No bevel necessary for skewed installation.

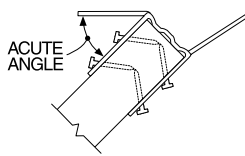

2. Skew flange to form acute angle. Bend other flange back. Bend along the centerline of slots. Bend one time only.

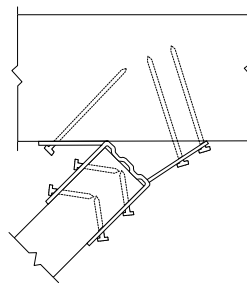

3. Attach hanger to header, acute angle first. Install nails at an angle.

THAI Minimum Nailing

MINIMUM OF 2 1/2" OF TOP FLANGE MATERIAL FOR MINIMUM NAILING CONFIGURATION

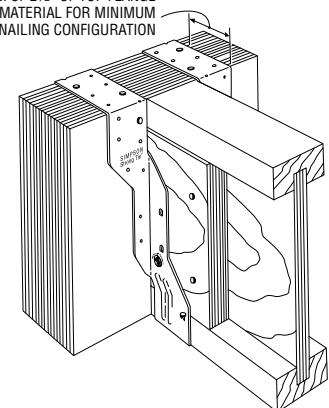

GENERAL CONNECTOR INSTALLATION



TB - Tension Bridging

Joist Height	Joist Spacing (Inches)								
	12	16	19.2	24	30	32	36	42	48
9½	TB20	TB27	TB27	TB30	TB36	TB36	TB42	TB48	TB54
11⅞	TB20	TB27	TB27	TB30	TB36	TB36	TB42	TB48	TB54
14	TB27	TB27	TB27	TB36	TB36	TB42	TB42	TB48	TB54
16	TB27	TB27	TB30	TB36	TB42	TB42	TB42	TB48	TB54

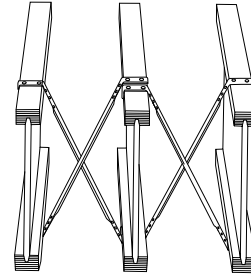

Typical TB Installation

VPA - Variable Pitch Connectors

Joist Width	Model No.	Fasteners		Factored Resistances							
		Top Plate	Rafter	Uplift (115)		Download (100)		Lateral (115)			
				DF	SPF	DF	SPF	DF		SPF	
				F ₁	F ₂	F ₁	F ₂	F ₁	F ₂	F ₁	F ₂
2½	VPA3	9-10d	2-10dx1½	545	390	1785	1785	625	415	615	415
3½	VPA4	11-10d	2-10dx1½	545	390	1785	1785	625	415	615	415

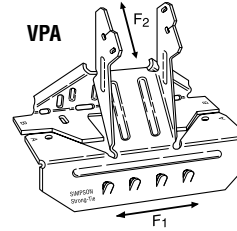

1. VPA's are not appropriate for applications that require more than 2" of bearing, such as intermediate supports.

VPA – 18 gauge
This variable pitch connector allows a sloped beam to sit on a top plate without having to notch, birdmouth, bevel, or toe nail. It also provides uplift capacity. Adjustable from 3:12 to 12:12 pitch.

STRONG-DRIVE® SCREW INSTALLATION FOR LVL

INSTALLATION

- Hex washer head allows for easy driving.
- Built-in reamer and the 4CUT™ tip means no pre-drilling required.
- See illustrations for SDS positioning on different assemblies.
- Install with high-torque, low speed drill (5 amp+).
- Do not over-drive the SDS screws.

DESIGN

- This document uses LVL values (SG = 0.50) and (SG = 0.42). Verify with LVL manufacturer specifications.
- Uniform loads in the table represent the capacity of the fasteners. The capacity of the LVL beam may be less and should be checked by a qualified designer or with the manufacturer's literature.
- The designer shall specify the location of all screws (stagger screws on opposite faces). Minimum recommended spacing—Wide Face: end distance 4", edge distance 1½", spacing parallel to grain 4", spacing perpendicular to grain 2½".

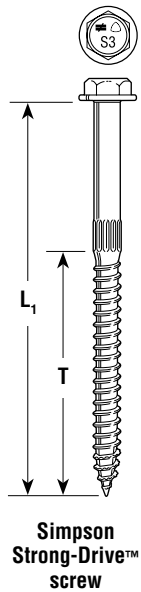

Simpson Strong-Drive™ screw

Screw Dimensions

Model	L ₁ (in)	T (in)	Head Stamp
SDS25312	3 1/2	2 1/4	S3.5
SDS25412	4 1/2	2 3/4	S4.5
SDS25600	6	3 1/4	S6

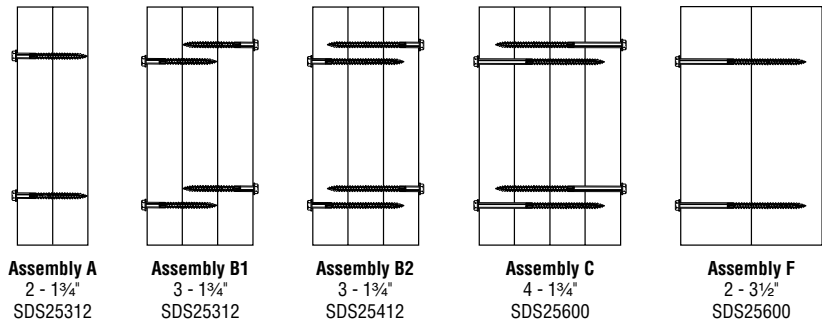

Assembly	SDS Screw Length	Side Member Thickness	Maximum Factored Uniform Load Applied to Outer Member (plf)					
			SDS @12" o/c		SDS @16" o/c		SDS @24" o/c	
			2-Rows	3-Rows	2-Rows	3-Rows	2-Rows	3-Rows
LVL (SG=0.50)								
A	3½	1¾	1220	1830	915	1370	610	915
B1	3½	1¾	915	1370	685	1030	455	685
B2	4½	1¾	1455	2180	1090	1635	725	1090
C	6	1¾	1040	1560	780	1170	520	780
F	6	3½	1220	1830	915	1375	610	915
LVL (SG=0.42)								
A	3½	1¾	1020	1530	765	1150	510	765
B1	3½	1¾	765	1145	575	860	380	575
B2	4½	1¾	1225	1835	920	1375	610	920
C	6	1¾	800	1200	600	900	400	600
F	6	3½	1040	1560	780	1170	520	780

1. If 7" wide beams are not equally loaded on each side, the load from the lesser side should be at least 25% of the opposite side.
2. Quantity and spacing of screws in table are for each screw head side of the assembly as shown in the Assembly figures above.
3. The design professional shall ensure that adequate lateral bracing is provided to prevent displacement of the beam due to the torsion created by the structural members framing into the side of the beam assembly.

Refer to the current Canadian Wood Construction Connectors catalogue for General Notes, Warranty Information and other important information, including Terms and Conditions of Sale, Building Code Evaluation listings and Corrosion Resistance.

© 2008 Simpson Strong-Tie Company Inc. • P.O. Box 10789, Pleasanton, CA 94588

CSG-BCCAN08 11/08 exp. 1/11 12/11

800-999-5099
www.strongtie.com