

CONNECTOR SELECTION GUIDE



FOR USE WITH PRODUCTS
MANUFACTURED BY:



This guide lists popular options for Simpson Strong-Tie hangers used with engineered wood products. Not all available hanger and installation combinations are listed. Use in conjunction with the current Simpson Strong-Tie Canadian **Wood Construction Connectors** catalogue for detailed hanger information.



LIMIT
STATES
DESIGN

800-999-5099
www.strongtie.com

DISTRIBUTED BY:

CSG-LPCAN09 2/09
exp. 1/11 12/11

CONNECTOR SELECTOR NOTES



General Notes

- See current Canadian *Wood Construction Connectors* catalogue for Important Information and General Notes section and for hanger models, joist sizes, and header situations not shown. See pages 10-11 for installation information.
- Unless otherwise noted, factored resistances (downloads) listed address hanger/header/fastener limitations assuming header material is Douglas Fir-Larch or Spruce Pine Fir. For LVL headers made primarily of Douglas Fir/Southern Pine, use the values found in the DF column. For LVL headers made primarily from Spruce Pine Fir or similar less dense veneers, use the values found in the SPF column. Loads are in pounds. Joist reaction should be checked by a qualified designer to ensure proper hanger selection.
- Factored uplift resistances (uplift) listed assume SPF joist and header and have been increased by 15% for earthquake and wind loading with no further increase allowed. Reduce loads according to code for normal duration loading such as cantilever construction.
- If hanger height is less than 60% of joist height, joist rotation may occur; see Prevent Rotation information below.
- Top flange hanger configuration and thickness of top flange need to be considered for flush frame conditions, see page 10.
- For this publication, carrying members are assumed to be at least 5½ inches tall. The horizontal thickness of the carrying member must be at least the length of nail being used or the hanger top flange dimension, whichever is greater.
Exception: narrower carrying members may be used with face mount hangers but the horizontal thickness must be at least 1¼ inches for 10d nails; 2 inches for 16d nails. Clinch nails on back side.
- THAI hangers in this publication are based on a “top flange” installation and require that the carrying member have a horizontal thickness of at least 2½ inches. Backer blocks are required when the header is an I-joist.
- All nails shown are common nails unless otherwise noted.
- I-joists that are used as headers require backer blocks. See Wood I-Joist Headers below for additional information.
- Multiple Members:** Multiple members should be adequately connected together to act as one unit.

Wood I-Joist Headers

I-Joist Headers: When supporting one I-joist from another, backer blocks must be used. Backer blocks are to be made from plywood, OSB, or dimension lumber. The thickness of a backer block should be the same thickness as the void in the side of the I-joist and a minimum of 12" wide. Attach with 10-10d common nails clinched as necessary, prior to installing the hanger. For Top Flange hangers, install backer blocks tight to top flange. For Face Mount hangers, install backer blocks tight to bottom flange. Refer to I-Joist manufacturer literature for specific guidelines.

Use 10d x 1½" nails for all Top Flange hangers attached to an I-joist header. See table for allowable loads.

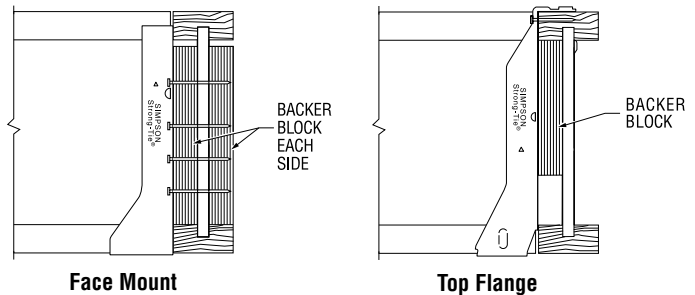

| Model | I-Joist Header Flange Material ¹ | |
|-------|---|------|
| | DF/SCL | SPF |
| ITS | 1375 | 1375 |
| LT | 1695 | 1695 |
| MIT | 1900 | 1900 |
| LBV | 2200 | 2200 |
| BA | 2420 | 2420 |

- For flanges with thicknesses from 1¾" to 1¾", use 0.85 of the I-joist header load. For flanges with thicknesses from 1½" to 1¼", use 0.75 of the I-joist header load.

Sloped Joists: For joists sloped up to ¼:12, regular (non-sloped) hangers may be used at full load value. For slopes greater than ¼:12, see adjacent table.

| Sloped Joist | | |
|--|------------|--------------|
| Model | Slope | Reduction |
| All Models | up to ¼:12 | no reduction |
| ITS, IUS, LT, LF, MIT, MIU, LBV, B, HB | up to ½:12 | 10% |
| WP, HW | up to ¾:12 | 15% |

For face mount hangers using 10d nails with headers less than 1¾" wide horizontally but at least 1½" wide, apply a reduction factor of 0.77 to all table loads.

Prevent Rotation

Hangers provide some joist rotation resistance; however, additional lateral restraint may be required for deep joists.

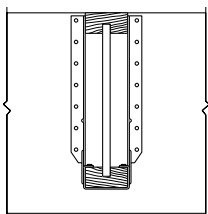

No Web Stiffener Installed
Hanger side flange supports joist top flange.

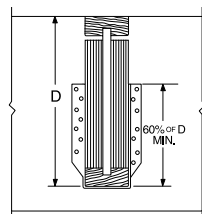

Web Stiffener Required
Hanger side flange should be at least 60% of joist depth or potential joist rotation must be addressed.

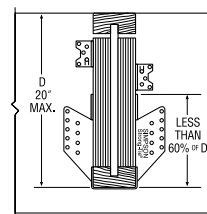

Rotation Resistance
If non-skewed hanger side flange is less than 60% of joist depth, attach staggered A34 framing anchors above the hanger.

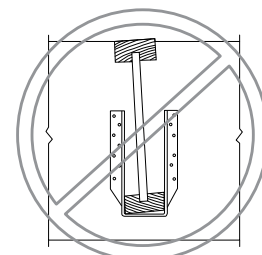

No Web Stiffener Results in Rotation
Hanger side flange is below the joist top flange. No web stiffener results in rotation, unless restrained by other means.

HOW TO PICK A HANGER

Follow these simple steps to choose your hanger:

| | |
|---|---|
| 1 | Find your joist size in this guide. |
| 2 | Choose your header type. Solid header or I-joist. <ul style="list-style-type: none">• Solid headers include solid sawn Douglas Fir, Spruce-Pine Fir, and LVL.• For I-joist header see page 2. |
| 3 | Locate your connector type in the table. <ul style="list-style-type: none">• Face mount, top flange, skewed, sloped, etc. |
| 4 | Select a hanger from the table. |
| 5 | Confirm that your factored joist reaction is less than the factored resistance of hanger. If yes, you have successfully selected your hanger. |
| | If you did not find a suitable hanger; Please see the current Canadian <i>Wood Construction Connectors</i> catalogue or call Simpson Strong-Tie at (800) 999-5099. You will need the following information: <ul style="list-style-type: none">• Download• Uplift• Header condition• Bearing length requirement |

SINGLE I-JOISTS – Canadian/Factored Resistance (lbs)



| Joist Height | Top Flange | | | | | | | Face Mount (Snap-In) | | | | | | | Face Mount | | | | | | |
|---|------------|-------|---------------|---------------|--------------|--------|------|----------------------|-------|---------------|-------|--------------|--------|------|------------|-------|---------------|---------------|--------------|--------|------|
| | Model | B Dim | Fastener Type | | Uplift (115) | Normal | | Model | B Dim | Fastener Type | | Uplift (115) | Normal | | Model | B Dim | Fastener Type | | Uplift (115) | Normal | |
| | | | Header | Joist | | DF | SPF | | | Header | Joist | | DF | SPF | | | Header | Joist | | DF | SPF |
| LPI 36 | | | | | | | | | | | | | | | | | | | | | |
| Joist Width = 2 1/4" | | | | | | | | | | | | | | | | | | | | | |
| 11 7/8 | LT231188 | 2 | 6-10d | 1-#8x1 1/4 WS | 100 | 2560 | 1725 | IUS2.37/11.88 | 2 | 10-10d | — | 105 | 2565 | 1835 | LF2311 | 2 | 12-10d | 1-#8x1 1/4 WS | 100 | 2880 | 2270 |
| 14 | LT2314 | 2 | 6-10d | 1-#8x1 1/4 WS | 100 | 2560 | 1725 | IUS2.37/14 | 2 | 12-10d | — | 105 | 2565 | 1835 | LF2314 | 2 | 14-10d | 1-#8x1 1/4 WS | 100 | 3235 | 2385 |
| 16 | LT2316 | 2 | 6-10d | 1-#8x1 1/4 WS | 100 | 2560 | 1725 | IUS2.37/16 | 2 | 14-10d | — | 105 | 2725 | 1950 | MIU2.37/16 | 2 1/2 | 24-16d | 2-10dx1 1/2 | 270 | 4695 | 3485 |
| LPI 20PLUS², LPI 32PLUS | | | | | | | | | | | | | | | | | | | | | |
| Joist Width = 2 1/4" | | | | | | | | | | | | | | | | | | | | | |
| 9 1/2 | LT259 | 2 | 6-10d | 1-#8x1 1/4 WS | 100 | 2560 | 1725 | IUS2.56/9.5 | 2 | 8-10d | — | 105 | 2385 | 1700 | LF259 | 2 | 10-10d | 1-#8x1 1/4 WS | 100 | 2525 | 2155 |
| 11 7/8 | LT251188 | 2 | 6-10d | 1-#8x1 1/4 WS | 100 | 2560 | 1725 | IUS2.56/11.88 | 2 | 10-10d | — | 105 | 2565 | 1835 | LF2511 | 2 | 12-10d | 1-#8x1 1/4 WS | 100 | 2880 | 2270 |
| 14 | LT2514 | 2 | 6-10d | 1-#8x1 1/4 WS | 100 | 2560 | 1725 | IUS2.56/14 | 2 | 12-10d | — | 105 | 2565 | 1835 | LF2514 | 2 | 14-10d | 1-#8x1 1/4 WS | 100 | 3235 | 2385 |
| 16 | LT2516 | 2 | 6-10d | 1-#8x1 1/4 WS | 100 | 2560 | 1725 | IUS2.56/16 | 2 | 14-10d | — | 105 | 2725 | 1950 | MIU2.56/16 | 2 1/2 | 24-16d | 2-10dx1 1/2 | 270 | 4930 | 3485 |
| LPI 42PLUS, LPI 56² | | | | | | | | | | | | | | | | | | | | | |
| Joist Width = 3 1/2" | | | | | | | | | | | | | | | | | | | | | |
| 9 1/2 | LT359 | 2 | 6-10d | 2-#8x1 1/4 WS | 100 | 2560 | 1725 | IUS3.56/9.5 | 2 | 10-10d | — | 105 | 2375 | 1695 | LF359 | 2 | 10-10d | 2-#8x1 1/4 WS | 100 | 2525 | 2155 |
| 11 7/8 | LT351188 | 2 | 6-10d | 2-#8x1 1/4 WS | 100 | 2560 | 1725 | IUS3.56/11.88 | 2 | 12-10d | — | 105 | 2375 | 1695 | LF3511 | 2 | 12-10d | 2-#8x1 1/4 WS | 100 | 2880 | 2270 |
| 14 | LT3514 | 2 | 6-10d | 2-#8x1 1/4 WS | 100 | 2560 | 1725 | IUS3.56/14 | 2 | 12-10d | — | 105 | 2375 | 1695 | LF3514 | 2 | 14-10d | 2-#8x1 1/4 WS | 100 | 3235 | 2385 |
| 16 | LT3516 | 2 | 6-10d | 2-#8x1 1/4 WS | 100 | 2560 | 1725 | IUS3.56/16 | 2 | 14-10d | — | 105 | 2375 | 1695 | MIU3.56/16 | 2 1/2 | 24-16d | 2-10dx1 1/2 | 270 | 4930 | 3485 |

1. Shaded hangers require web stiffeners at joist ends. Web stiffeners may be required by others for non-shaded hangers.
2. Joist types may not be available in all depths shown on table, check with manufacturer.
3. THAI hangers require a minimum of 4 top and 2 face nails installed. (See note 7, page 2)
4. See page 2, note 2 for header definitions.
5. WS = wood screw

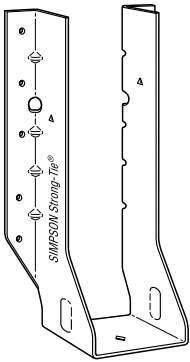

LF

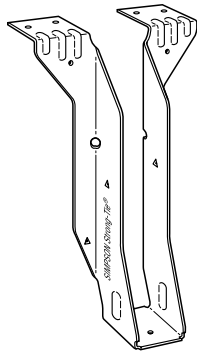

LT

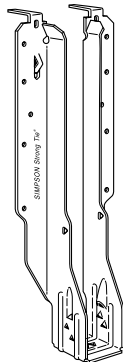

IUS

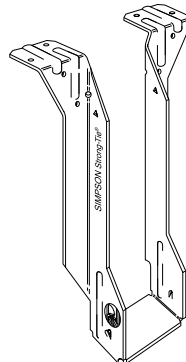

MIT

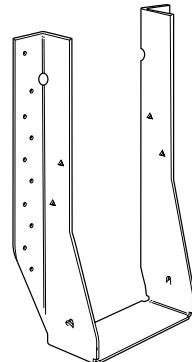

MIU

LF – 18 gauge
LT – 18 gauge
 The LF and LT series feature fast and easy installation. No web stiffeners required and only one screw secures joist in hanger.

IUS – 18 gauge
 The IUS is a new hybrid hanger that incorporates the advantages of face-mount and top-flange hangers. Joist nails are not required.

MIT – 16 gauge
 The MIT's Positive Angle Nailing helps minimize splitting of the I-joists' bottom flange. Features uplift capacity and extended seat design (to allow installation of slightly undercut joists).

MIU – 16 gauge
 The MIU series features 16 gauge steel and extra nailing for higher loads than the LF.

SINGLE I-JOISTS – Canadian/Factored Resistance (lbs)



| Joist Height | 45° Skew | | | | | | | Adjustable Height | | | | | | | Field Slope & Skew | | | | | | | |
|---------------------------------------|--------------|--------|---------------|-------------|--------------|--------|------|--|-------|---------------|-------|--------------|--------|--|--------------------|----------|---------------|--------|--------------|--------|------|------|
| | Model | B Dim | Fastener Type | | Uplift (115) | Normal | | Model | B Dim | Fastener Type | | Uplift (115) | Normal | | Model | B Dim | Fastener Type | | Uplift (115) | Normal | | |
| | | | Header | Joist | | DF | SPF | | | Header | Joist | | DF | SPF | | | Header | Joist | | DF | SPF | |
| | | | | | | | | | | | | | | | | | | | | | | Top |
| LPI 36 | | | | | | | | | | | | | | | | | | | | | | |
| Joist Width = 2 1/2" | | | | | | | | | | | | | | | | | | | | | | |
| 11 1/2 | SUR/L2.37/11 | 3 3/16 | 16-16d | 2-10dx1 1/2 | 385 | 3945 | 2780 | THAI3522 ³ | 2 1/4 | 4-10d | 2-10d | 2-10dx1 1/2 | — | 2740 | 2075 | LSSUI35 | 3 1/2 | 9-10d | 7-10dx1 1/2 | 915 | 2090 | 1495 |
| 14 | SUR/L2.37/14 | 3 3/16 | 18-16d | 2-10dx1 1/2 | 385 | 3945 | 2780 | THAI3522 ³ | 2 1/4 | 4-10d | 2-10d | 2-10dx1 1/2 | — | 2740 | 2075 | LSSUI35 | 3 1/2 | 9-10d | 7-10dx1 1/2 | 915 | 2090 | 1495 |
| 16 | SUR/L2.37/14 | 3 3/16 | 18-16d | 2-10dx1 1/2 | 385 | 3945 | 2780 | See Canadian <i>Wood Construction Connectors</i> catalogue for hanger selection. | | | | | | See Canadian <i>Wood Construction Connectors</i> catalogue for hanger selection. | | | | | | | | |
| LPI 20PLUS², 32PLUS | | | | | | | | | | | | | | | | | | | | | | |
| Joist Width = 2 1/2" | | | | | | | | | | | | | | | | | | | | | | |
| 9 1/2 | SUR/L2.56/9 | 3 3/16 | 14-16d | 2-10dx1 1/2 | 385 | 3945 | 2780 | THAI322 ³ | 2 1/4 | 4-10d | 2-10d | 2-10dx1 1/2 | — | 2740 | 2075 | LSSUH310 | 3 1/2 | 14-16d | 12-10dx1 1/2 | 1220 | 2620 | 1850 |
| 11 1/2 | SUR/L2.56/11 | 3 3/16 | 16-16d | 2-10dx1 1/2 | 385 | 3945 | 2780 | THAI322 ³ | 2 1/4 | 4-10d | 2-10d | 2-10dx1 1/2 | — | 2740 | 2075 | LSSUH310 | 3 1/2 | 14-16d | 12-10dx1 1/2 | 1220 | 2620 | 1850 |
| 14 | SUR/L2.56/14 | 3 3/16 | 18-16d | 2-10dx1 1/2 | 385 | 3945 | 2780 | THAI322 ³ | 2 1/4 | 4-10d | 2-10d | 2-10dx1 1/2 | — | 2740 | 2075 | LSSUH310 | 3 1/2 | 14-16d | 12-10dx1 1/2 | 1220 | 2620 | 1850 |
| 16 | SUR/L2.56/14 | 3 3/16 | 18-16d | 2-10dx1 1/2 | 385 | 3945 | 2780 | See Canadian <i>Wood Construction Connectors</i> catalogue for hanger selection. | | | | | | See Canadian <i>Wood Construction Connectors</i> catalogue for hanger selection. | | | | | | | | |
| LPI 42PLUS, LP I56² | | | | | | | | | | | | | | | | | | | | | | |
| Joist Width = 3 1/2" | | | | | | | | | | | | | | | | | | | | | | |
| 9 1/2 | SUR/L410 | 2 5/8 | 14-16d | 6-16d | 1395 | 4065 | 2875 | THAI422 ³ | 2 1/4 | 4-10d | 2-10d | 2-10dx1 1/2 | — | 2740 | 2075 | LSSU410 | 3 1/2 | 14-16d | 12-10dx1 1/2 | 1220 | 3055 | 2160 |
| 11 1/2 | SUR/L410 | 2 5/8 | 14-16d | 6-16d | 1395 | 4065 | 2875 | THAI422 ³ | 2 1/4 | 4-10d | 2-10d | 2-10dx1 1/2 | — | 2740 | 2075 | LSSU410 | 3 1/2 | 14-16d | 12-10dx1 1/2 | 1220 | 3055 | 2160 |
| 14 | SUR/L414 | 2 1/2 | 18-16d | 8-16d | 1555 | 4095 | 2895 | THAI422 ³ | 2 1/4 | 4-10d | 2-10d | 2-10dx1 1/2 | — | 2740 | 2075 | LSSU410 | 3 1/2 | 14-16d | 12-10dx1 1/2 | 1220 | 3055 | 2160 |
| 16 | SUR/L414 | 2 1/2 | 18-16d | 8-16d | 1555 | 4095 | 2895 | See Canadian <i>Wood Construction Connectors</i> catalogue for hanger selection. | | | | | | See Canadian <i>Wood Construction Connectors</i> catalogue for hanger selection. | | | | | | | | |

1. See notes on page 4.

| Specified Nail | CSA 086-01 Nail |
|----------------|--------------------|
| 8d | 2 1/2" common wire |
| 10d | 3" common wire |
| 16d | 3 1/2" common wire |

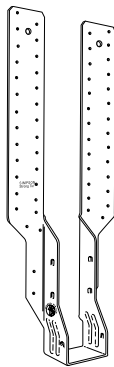

THAI

THAI – 18 gauge
This hanger has extra long straps and can be field-formed to give height adjustability and top flange hanger convenience. Positive angle nailing helps minimize splitting of the I-joist's bottom flange. Minimum nailing is shown in the table above. Strap must be field-formed over the top of the header by a minimum of 2 1/2". Web stiffeners required when used with I-joists.

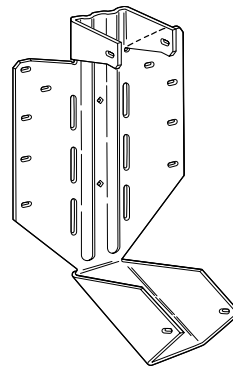

LSSU

LSSU, LSSUI – 18 gauge
LSSU210-2, LSSU410, and LSSUH310 – 16 gauge
LSU – 14 gauge
LSSU models provide uplift capacity and can be field sloped and/or skewed to 45°. Web stiffeners required when used with I-joists; cut web stiffener to match angle on sloped conditions.

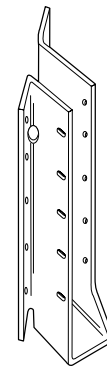

SUL

SUR/L, SUR/L1 – 16 gauge
HSUR/L – 14 gauge
All models are skewed 45°. Normally accommodates a 40° - 50° skew. The installation of these hangers does not require a beveled end cut.

DOUBLE I-JOISTS – Canadian/Factored Resistance (lbs)



| Joist Height | Top Flange | | | | | | Face Mount | | | | | | 45° Skew | | | | | | | | |
|--|--------------|-------|---------------|----------|--------------|--------|------------|------------|-------|---------------|----------|--------------|----------|------|-----------------------|---------------------------------|---------------|----------|--------------|--------|------|
| | Model | B Dim | Fastener Type | | Uplift (115) | Normal | | Model | B Dim | Fastener Type | | Uplift (115) | Normal | | Model | B Dim | Fastener Type | | Uplift (115) | Normal | |
| | | | Header | Joist | | DF | SPF | | | Header | Joist | | DF | SPF | | | Header | Joist | | DF | SPF |
| Double LPI 36 | | | | | | | | | | | | | | | | | | | | | |
| Joist Width = 4½" | | | | | | | | | | | | | | | | | | | | | |
| 11½ | MIT3511.88-2 | 2½ | 8-16d | 2-10dx1½ | 380 | 3480 | 2415 | MIU4.75/11 | 2½ | 20-16d | 2-10dx1½ | 270 | 4550 | 3215 | HSUR/L4.75/11 | 2¾ | 16-16d | 2-10dx1½ | 195 | 4195 | 2965 |
| 14 | MIT3514-2 | 2½ | 8-16d | 2-10dx1½ | 380 | 3480 | 2415 | MIU4.75/14 | 2½ | 22-16d | 2-10dx1½ | 270 | 4930 | 3485 | HSUR/L4.75/14 | 2¾ | 20-16d | 2-10dx1½ | 195 | 4195 | 2965 |
| 16 | MIT4.75/16 | 2½ | 8-16d | 2-10dx1½ | 380 | 3480 | 2415 | MIU4.75/16 | 2½ | 24-16d | 2-10dx1½ | 270 | 4930 | 3485 | HSUR/L4.75/16 | 2¾ | 24-16d | 2-10dx1½ | 195 | 4195 | 2965 |
| Double LPI 20PLUS³, LPI 32PLUS | | | | | | | | | | | | | | | | | | | | | |
| Joist Width = 5" | | | | | | | | | | | | | | | | | | | | | |
| 9½ | MIT39.5-2 | 2½ | 8-16d | 2-10dx1½ | 380 | 3480 | 2415 | MIU5.12/9 | 2½ | 16-16d | 2-10dx1½ | 270 | 4550 | 3215 | HSUR/L5.12/9 | 2 ¹³ / ₁₆ | 12-16d | 2-10dx1½ | 195 | 2995 | 2350 |
| 11½ | MIT311.88-2 | 2½ | 8-16d | 2-10dx1½ | 380 | 3480 | 2415 | MIU5.12/11 | 2½ | 20-16d | 2-10dx1½ | 270 | 4550 | 3215 | HSUR/L5.12/11 | 2 ¹³ / ₁₆ | 16-16d | 2-10dx1½ | 195 | 4195 | 2965 |
| 14 | MIT314-2 | 2½ | 8-16d | 2-10dx1½ | 380 | 3480 | 2415 | MIU5.12/14 | 2½ | 22-16d | 2-10dx1½ | 270 | 4930 | 3485 | HSUR/L5.12/14 | 2 ¹³ / ₁₆ | 20-16d | 2-10dx1½ | 195 | 4195 | 2965 |
| 16 | MIT5.12/16 | 2½ | 8-16d | 2-10dx1½ | 380 | 3480 | 2415 | MIU5.12/16 | 2½ | 24-16d | 2-10dx1½ | 270 | 4930 | 3485 | HSUR/L5.12/16 | 2 ¹³ / ₁₆ | 24-16d | 2-10dx1½ | 195 | 4195 | 2965 |
| Double LPI 42PLUS, LPI 56³ | | | | | | | | | | | | | | | | | | | | | |
| Joist Width = 7" | | | | | | | | | | | | | | | | | | | | | |
| 9½ | B7.12/9.5 | 2½ | 14-16d | 6-16d | 1170 | 5940 | 3910 | HU410-2 | 2½ | 18-16d | 8-16d | 1865 | 5780 | 4670 | HU410-2X ² | 2½ | 18-16d | 8-16d | 1400 | 3755 | 3035 |
| 11½ | B7.12/11.88 | 2½ | 14-16d | 6-16d | 1170 | 5940 | 3910 | HU412-2 | 2½ | 22-16d | 8-16d | 1865 | 5780 | 4670 | HU412-2X ² | 2½ | 22-16d | 8-16d | 1400 | 3755 | 3035 |
| 14 | B7.12/14 | 2½ | 14-16d | 6-16d | 1170 | 5940 | 3910 | HU414-2 | 2½ | 26-16d | 12-16d | 2685 | 7025 | 5780 | HU414-2X ² | 2½ | 26-16d | 12-16d | 2015 | 4565 | 3755 |
| 16 | B7.12/16 | 2½ | 14-16d | 6-16d | 1170 | 5940 | 3910 | HU414-2 | 2½ | 26-16d | 12-16d | 2685 | 7025 | 5780 | HU414-2X ² | 2½ | 26-16d | 12-16d | 2015 | 4565 | 3755 |

1. Shaded hangers require web stiffeners at joist ends. Web stiffeners may be required by others for non-shaded hangers.
2. Skewed option must be special ordered. Specify skew angle and direction (e.g. U3512-2X SKR45°).
3. Joist types may not be available in all depths shown on table, check with manufacturer.
4. LSSU4.12, LSU5.12, and LSU3510-2 are **field sloped only**. Skewed option must be special ordered. Specify skew angle
5. THAI hangers require a minimum of 4 top and 2 face nails installed. THAI-2 must be special ordered. Specify width between 3¹/₁₆" and 5⁵/₁₆".
6. See page 2, note 2 for header definitions.

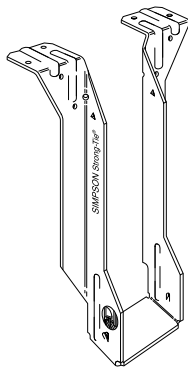

MIT

MIT – 16 gauge
The MIT's Positive Angle Nailing helps minimize splitting of the I-joists' bottom flange. Features uplift capacity and extended seat design (to allow installation of slightly undercut joists).

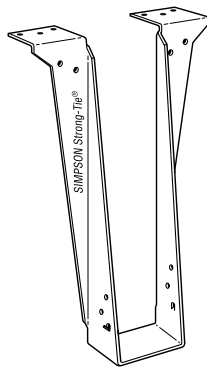

LBV

LBV – 14 gauge
The LBV is designed especially for use with multiple ply headers 1½" to 1¾" thick, and may be used for weld-on applications.

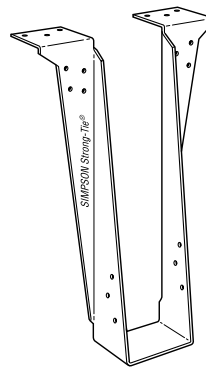

B

B – 12 gauge
The B series offers versatility for I-joists and SCL lumber. Enhanced load capacity widens the range of applications for these hangers.

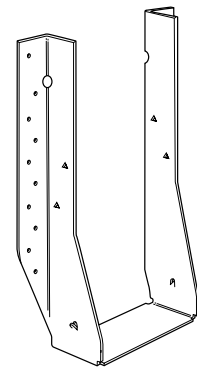

MIU

MIU – 16 gauge
The MIU series features 16 gauge steel and extra nailing for higher loads than the IUT.

DOUBLE I-JOISTS – Canadian/Factored Resistance (lbs)



| Joist Height | Adjustable Height | | | | | | | | Field Slope & Skew | | | | | | | |
|---|--|-------|---------------|-------|-------------|--------------|--------|------|--|-------|---------------|--------------|--------------|--------|------|--|
| | Model | B Dim | Fastener Type | | | Uplift (115) | Normal | | Model | B Dim | Fastener Type | | Uplift (115) | Normal | | |
| | | | Header | | Joist | | DF | SPF | | | Header | Joist | | DF | SPF | |
| | | | Top | Face | | | | | | | | | | | | |
| Double LPI 36 Joist Width = 4 1/2" | | | | | | | | | | | | | | | | |
| 11 7/8 | THAI-2 ⁵ | 2 1/2 | 4-10d | 2-10d | 2-10dx1 1/2 | — | 2935 | 2935 | LSU3510-2 ⁴ | 3 1/2 | 24-16d | 16-10dx1 1/2 | 1385 | 3765 | 2665 | |
| 14 | THAI-2 ⁵ | 2 1/2 | 4-10d | 2-10d | 2-10dx1 1/2 | — | 2935 | 2935 | LSU3510-2 ⁴ | 3 1/2 | 24-16d | 16-10dx1 1/2 | 1385 | 3765 | 2665 | |
| 16 | See Canadian <i>Wood Construction Connectors</i> catalogue for hanger selection. | | | | | | | | See Canadian <i>Wood Construction Connectors</i> catalogue for hanger selection. | | | | | | | |
| Double LPI 20PLUS³, LPI 32PLUS Joist Width = 5" | | | | | | | | | | | | | | | | |
| 9 1/2 | THAI-2 ⁵ | 2 1/2 | 4-10d | 2-10d | 2-10dx1 1/2 | — | 2935 | 2935 | LSU5.12 ⁴ | 3 1/2 | 24-16d | 16-10dx1 1/2 | 910 | 2600 | 1835 | |
| 11 7/8 | THAI-2 ⁵ | 2 1/2 | 4-10d | 2-10d | 2-10dx1 1/2 | — | 2935 | 2935 | LSU5.12 ⁴ | 3 1/2 | 24-16d | 16-10dx1 1/2 | 910 | 2600 | 1835 | |
| 14 | THAI-2 ⁵ | 2 1/2 | 4-10d | 2-10d | 2-10dx1 1/2 | — | 2935 | 2935 | LSU5.12 ⁴ | 3 1/2 | 24-16d | 16-10dx1 1/2 | 910 | 2600 | 1835 | |
| 16 | See Canadian <i>Wood Construction Connectors</i> catalogue for hanger selection. | | | | | | | | See Canadian <i>Wood Construction Connectors</i> catalogue for hanger selection. | | | | | | | |
| Double LPI 42PLUS, LPI 56³ Joist Width = 7" | | | | | | | | | | | | | | | | |
| 9 1/2 | See Canadian <i>Wood Construction Connectors</i> catalogue for hanger selection. | | | | | | | | See Canadian <i>Wood Construction Connectors</i> catalogue for hanger selection. | | | | | | | |
| 11 7/8 | | | | | | | | | | | | | | | | |
| 14 | | | | | | | | | | | | | | | | |
| 16 | | | | | | | | | | | | | | | | |

1. See notes on page 6.

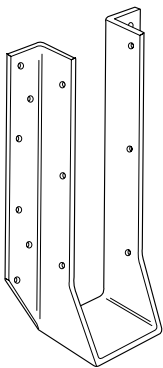

HU

HU – 14 gauge
The HU series features uplift capacity and a large selection of sizes and load ranges. HU hangers have triangle holes that can be filled for increased loads. Web stiffeners required when used with I-joists.

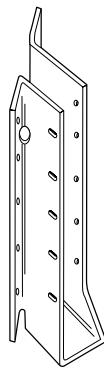

SUL

SUR/L – 16 gauge
HSUR/L – 14 gauge
All models are skewed 45°. Normally accommodates a 40°- 50° skew. The installation of these hangers does not require a beveled end cut.

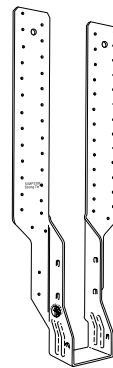

THAI

THAI – 18 gauge
THAI-2 – 14 gauge
This hanger has extra long straps and can be field-formed to give height adjustability and top flange hanger convenience. Positive angle nailing helps minimize splitting of the I-joist's bottom flange. Minimum nailing is shown in the table above. Strap must be field-formed over the top of the header by a minimum of 2 1/2". Web stiffeners required when used with I-joists.

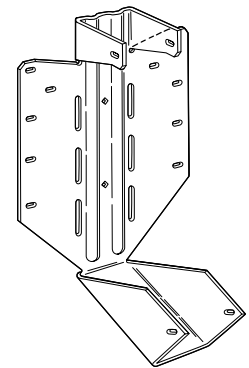

LSSU

LSSU/LSSUI – 18 gauge
LSSU210-2, LSSU410 – 16 gauge
LSU – 14 gauge
LSSU models provide uplift capacity and can be field sloped and/or skewed to 45°. Web stiffeners required when used with I-joists.

BEAMS and HEADERS – Canadian/Factored Resistance (lbs)



| Joist Height | Top Flange | | | | | | Face Mount | | | | | | | |
|---|---------------|-------|---------------|-------------|--------------|--------|------------|------------|-------|---------------|--------------|--------------|--------|-------|
| | Model | B Dim | Fastener Type | | Uplift (115) | Normal | | Model | B Dim | Fastener Type | | Uplift (115) | Normal | |
| | | | Header | Joist | | DF | SPF | | | Header | Joist | | DF | SPF |
| 1 3/4" LP LVL | | | | | | | | | | | | | | |
| 7 1/4 | LBV1.81/7.25 | 3 | 10-16d | 2-10dx1 1/2 | 310 | 3905 | 3125 | HU7 | 2 1/2 | 16-16d | 8-10dx1 1/2 | 1555 | 5445 | 4040 |
| 9 1/4 | LBV1.81/9.25 | 3 | 10-16d | 2-10dx1 1/2 | 310 | 3905 | 3125 | HU7 | 2 1/2 | 16-16d | 8-10dx1 1/2 | 1555 | 5445 | 4040 |
| | WPU1.81/9.25 | 4 | 7-16d | 6-10dx1 1/2 | 770 | 6390 | 6390 | HUS1.81/10 | 3 | 30-16d | 10-16d | 3875 | 7130 | 5255 |
| 9 1/2 | MIT9.5 | 2 1/2 | 8-16d | 2-10dx1 1/2 | 380 | 3480 | 2415 | HU9 | 2 1/2 | 24-16d | 10-10dx1 1/2 | 1940 | 5780 | 4380 |
| | LBV1.81/9.5 | 3 | 10-16d | 2-10dx1 1/2 | 310 | 3905 | 3125 | HUS1.81/10 | 3 | 30-16d | 10-16d | 3875 | 7130 | 5255 |
| 11 1/4 | LBV1.81/11.25 | 3 | 10-16d | 2-10dx1 1/2 | 310 | 3905 | 3125 | HU11 | 2 1/2 | 30-16d | 10-10dx1 1/2 | 1940 | 5780 | 4380 |
| | WPU1.81/11.25 | 4 | 7-16d | 6-10dx1 1/2 | 770 | 6390 | 6390 | HUS1.81/10 | 3 | 30-16d | 10-16d | 3875 | 7130 | 5255 |
| 11 7/8 | MIT11.88 | 2 1/2 | 8-16d | 2-10dx1 1/2 | 380 | 3480 | 2415 | HU11 | 2 1/2 | 30-16d | 10-10dx1 1/2 | 1940 | 5780 | 4380 |
| | BA1.81/11.88 | 3 | 16-16d | 8-10dx1 1/2 | 1360 | 5940 | 4370 | HUS1.81/10 | 3 | 30-16d | 10-16d | 3875 | 7130 | 5255 |
| 14 | MIT1.81/14 | 2 1/2 | 8-16d | 2-10dx1 1/2 | 380 | 3480 | 2415 | HU14 | 2 1/2 | 36-16d | 14-10dx1 1/2 | 2685 | 5780 | 5055 |
| | LBV1.81/14 | 3 | 10-16d | 2-10dx1 1/2 | 310 | 3905 | 3125 | HUS1.81/10 | 3 | 30-16d | 10-16d | 3875 | 7130 | 5255 |
| 16 | MIT1.81/16 | 2 1/2 | 8-16d | 2-10dx1 1/2 | 380 | 3480 | 2415 | MIU1.81/16 | 2 1/2 | 24-16d | 2-10dx1 1/2 | 270 | 3555 | 2690 |
| | B1.81/16 | 3 | 14-16d | 6-10dx1 1/2 | 1170 | 5940 | 3910 | HUS1.81/10 | 3 | 30-16d | 10-16d | 3875 | 7130 | 5255 |
| 18 | LBV1.81X | 3 | 10-16d | 2-10dx1 1/2 | 310 | 3905 | 3125 | MIU1.81/18 | 2 1/2 | 26-16d | 2-10dx1 1/2 | 270 | 3555 | 2690 |
| | HB1.81X | 3 1/2 | 22-16d | 2-10dx1 1/2 | 2345 | 9335 | 5945 | HUS1.81/10 | 3 | 30-16d | 10-16d | 3875 | 7130 | 5255 |
| 2 Ply 1 3/4" LP LVL or 3 1/2" LP LVL | | | | | | | | | | | | | | |
| 7 1/4 | LBV3.56/7.25 | 2 1/2 | 10-16d | 2-10dx1 1/2 | 310 | 3905 | 3125 | HHUS48 | 3 | 22-16d | 8-16d | 2665 | 8945 | 6320 |
| 9 1/4 | LBV3.56/9.25 | 2 1/2 | 10-16d | 2-10dx1 1/2 | 310 | 3905 | 3125 | HHUS410 | 3 | 30-16d | 10-16d | 3875 | 9860 | 6970 |
| | HB3.56/9.25 | 3 1/2 | 22-16d | 10-16d | 2345 | 9335 | 5945 | HGUS410 | 4 | 46-16d | 16-16d | 4835 | 14645 | 10355 |
| 9 1/2 | LBV3.56/9.5 | 2 1/2 | 10-16d | 2-10dx1 1/2 | 310 | 3905 | 3125 | HHUS410 | 3 | 30-16d | 10-16d | 3875 | 9860 | 6970 |
| | HB3.56/9.5 | 3 1/2 | 22-16d | 10-16d | 2345 | 9335 | 5945 | HGUS410 | 4 | 46-16d | 16-16d | 4835 | 14645 | 10355 |
| 11 1/4 | LBV3.56/11.25 | 2 1/2 | 10-16d | 2-10dx1 1/2 | 310 | 3905 | 3125 | HHUS410 | 3 | 30-16d | 10-16d | 3875 | 9860 | 6970 |
| | HB3.56/11.25 | 3 1/2 | 22-16d | 10-16d | 2345 | 9335 | 5945 | HGUS412 | 4 | 56-16d | 20-16d | 5400 | 14995 | 10595 |
| 11 7/8 | BA3.56/11.88 | 3 | 16-16d | 8-10dx1 1/2 | 1360 | 5940 | 4370 | HHUS410 | 3 | 30-16d | 10-16d | 3875 | 9860 | 6970 |
| | HB3.56/11.88 | 3 1/2 | 22-16d | 10-16d | 2345 | 9335 | 5945 | HGUS412 | 4 | 56-16d | 20-16d | 5400 | 14995 | 10595 |
| 14 | BA3.56/14 | 3 | 16-16d | 8-10dx1 1/2 | 1360 | 5940 | 4370 | HHUS410 | 3 | 30-16d | 10-16d | 3875 | 9860 | 6970 |
| | SCL3.62/14 | 4 | 6-16d | 6-16d | 1405 | 13395 | 6775 | HGUS414 | 4 | 66-16d | 22-16d | 7160 | 16400 | 11595 |
| 16 | BA3.56/16 | 3 | 16-16d | 8-10dx1 1/2 | 1360 | 5940 | 4370 | HGUS414 | 4 | 66-16d | 22-16d | 7160 | 16400 | 11595 |
| | SCL3.62/16 | 4 | 6-16d | 6-16d | 1405 | 13395 | 6775 | HGUS414 | 4 | 66-16d | 22-16d | 7160 | 16400 | 11595 |
| 18 | HB3.56/18 | 3 1/2 | 22-16d | 10-16d | 2345 | 9335 | 5945 | HGUS414 | 4 | 66-16d | 22-16d | 7160 | 16400 | 11595 |
| | SCL3.62/18 | 5 | 12-16d | 12-16d | 2620 | 17600 | 11490 | HGUS414 | 4 | 66-16d | 22-16d | 7160 | 16400 | 11595 |

1. Normal load column for top flange hangers represents floor loads (100%) and may not be increased for other load durations.
2. HU hangers use both round and triangle holes.
3. When ordering HGU or HHGU specify height.

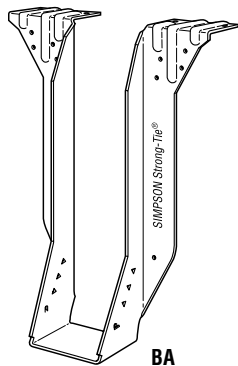

BA

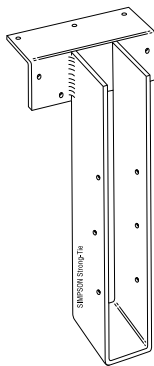

WPU

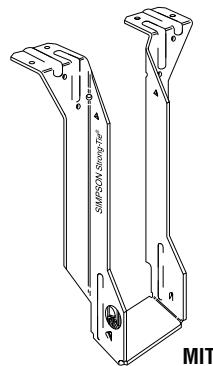

MIT

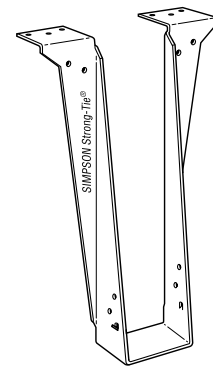

LBV

BA – 14 gauge
The BA series offers versatility for I-joists and SCL lumber. Enhanced load capacity widens the range of applications for these hangers.

W, WI – Top flange – 12 gauge;
Stirrup – 12 gauge
WP, WPI, WPU – Top flange – 7 gauge;
Stirrup – 12 gauge
HWU – Top flange – 3 gauge; Stirrup – 10 gauge
This welded series offers the greatest design flexibility and versatility, and a large selection of sizes. Suitable for welded and nailer applications, and modifications including slopes and skews.

MIT – 16 gauge
The MIT's Positive Angle Nailing helps minimize splitting of the I-joists' bottom flange. Features uplift capacity and extended seat design (to allow installation of slightly undercut joists).

LBV – 14 gauge
The LBV is designed especially for use with multiple ply headers 1 1/2" to 1 3/4" thick, and may be used for weld-on applications.

BEAMS and HEADERS – Canadian/Factored Resistance (lbs)



| Joist Height | Top Flange | | | | | | | Face Mount | | | | | | |
|---|----------------|-------|---------------|-------------|--------------|--------|-------|---------------------------|--------|------------------|------------------|--------------|--------|-------|
| | Model | B Dim | Fastener Type | | Uplift (115) | Normal | | Model | B Dim | Fastener Type | | Uplift (115) | Normal | |
| | | | Header | Joist | | DF | SPF | | | Header | Joist | | DF | SPF |
| 3 Ply 1 3/4" LP LVL or 5 1/4" LP LVL | | | | | | | | | | | | | | |
| 7 1/4 | WPU5.50/7.25 | 3 | 7-16d | 6-10dx1 1/2 | 770 | 6390 | 6390 | HGUS5.50/8 | 4 | 36-16d | 12-16d | 4290 | 12980 | 9175 |
| 9 1/4 | HB5.50/9.25 | 3 1/2 | 22-16d | 10-16d | 2345 | 9335 | 5945 | HHUS5.50/10 | 3 | 30-16d | 10-16d | 3875 | 9860 | 6970 |
| | GLTV5.50/9.25 | 5 | 10-16d | 6-16d | 1405 | 10455 | 7470 | HGUS5.50/10 | 4 | 46-16d | 16-16d | 4835 | 14645 | 10355 |
| 9 1/2 | HB5.50/9.5 | 3 1/2 | 22-16d | 10-16d | 2345 | 9335 | 5945 | HHUS5.50/10 | 3 | 30-16d | 10-16d | 3875 | 9860 | 6970 |
| | SCL5.37/9.5 | 4 | 6-16d | 6-16d | 1405 | 13395 | 6775 | HGUS5.50/10 | 4 | 46-16d | 16-16d | 4835 | 14645 | 10355 |
| 11 1/4 | HB5.50/11.25 | 3 1/2 | 22-16d | 10-16d | 2345 | 9335 | 5945 | HHUS5.50/10 | 3 | 30-16d | 10-16d | 3875 | 9860 | 6970 |
| | GLTV5.50/11.25 | 5 | 10-16d | 6-16d | 1405 | 10455 | 7470 | HGUS5.50/12 | 4 | 56-16d | 20-16d | 5400 | 14995 | 10595 |
| 11 1/8 | HB5.50/11.88 | 3 1/2 | 22-16d | 10-16d | 2345 | 9335 | 5945 | HHUS5.50/10 | 3 | 30-16d | 10-16d | 3875 | 9860 | 6970 |
| | SCL5.37/11.88 | 5 | 12-16d | 12-16d | 2620 | 17600 | 11490 | HGUS5.50/12 | 4 | 56-16d | 20-16d | 5400 | 14995 | 10595 |
| 14 | HB5.50/14 | 3 1/2 | 22-16d | 10-16d | 2345 | 9335 | 5945 | HHUS5.50/10 | 3 | 30-16d | 10-16d | 3875 | 9860 | 6970 |
| | SCL5.37/14 | 5 | 12-16d | 12-16d | 2620 | 17600 | 11490 | HGUS5.50/14 | 4 | 66-16d | 22-16d | 7160 | 16400 | 11595 |
| 16 | HGLTV5.516 | 6 | 18-16d | 6-16d | 1405 | 13070 | 9830 | HGUS5.50/14 | 4 | 66-16d | 22-16d | 7160 | 16400 | 11595 |
| | SCL5.37/16 | 6 | 10-16d | 12-16d | 2345 | 23680 | 13025 | HGU5.50-SDS ³ | 5 1/4 | 36-SDS 1/4x2 1/2 | 24-SDS 1/4x2 1/2 | 9300 | 20320 | 18020 |
| 18 | SCL5.37/18 | 6 | 10-16d | 12-16d | 2345 | 23680 | 13025 | HGUS5.50/14 | 4 | 66-16d | 22-16d | 7160 | 16400 | 11595 |
| | | | | | | | | HGU5.50-SDS ³ | 5 1/4 | 36-SDS 1/4x2 1/2 | 24-SDS 1/4x2 1/2 | 9300 | 20320 | 18020 |
| 4 Ply 1 3/4" LP LVL or 7" LP LVL | | | | | | | | | | | | | | |
| 9 1/4 | HB7.12/9.25 | 3 1/2 | 22-16d | 10-16d | 2345 | 9335 | 5945 | HHUS7.25/10 | 3 9/16 | 30-16d | 10-16d | 3875 | 10780 | 7620 |
| | GLTV49.25-2 | 5 | 10-16d | 6-16d | 1405 | 10455 | 7470 | HGUS7.25/10 | 4 | 46-16d | 16-16d | 4835 | 15760 | 11140 |
| 9 1/2 | HB7.12/9.5 | 3 1/2 | 22-16d | 10-16d | 2345 | 9335 | 5945 | HHUS7.25/10 | 3 9/16 | 30-16d | 10-16d | 3875 | 10780 | 7620 |
| | SCL7.25/9.5 | 4 | 6-16d | 6-16d | 1405 | 13395 | 6775 | HGUS7.25/10 | 4 | 46-16d | 16-16d | 4835 | 15760 | 11140 |
| 11 1/4 | GLTV411.25-2 | 5 | 10-16d | 6-16d | 1405 | 10455 | 7470 | HHUS7.25/10 | 3 9/16 | 30-16d | 10-16d | 3875 | 10780 | 7620 |
| | HGLTV411.25-2 | 6 | 18-16d | 6-16d | 1405 | 13070 | 9830 | HGUS7.25/12 | 4 | 56-16d | 20-16d | 5400 | 16110 | 11385 |
| 11 1/8 | HGLTV411.88-2 | 6 | 18-16d | 6-16d | 1405 | 13070 | 9830 | HHUS7.25/10 | 3 9/16 | 30-16d | 10-16d | 3875 | 10780 | 7620 |
| | SCL7.25/11.88 | 5 | 12-16d | 12-16d | 2620 | 17600 | 11490 | HGUS7.25/12 | 4 | 56-16d | 20-16d | 5400 | 16110 | 11385 |
| 14 | SCL7.25/14 | 5 | 12-16d | 12-16d | 2620 | 17600 | 11490 | HGUS7.25/14 | 4 | 66-16d | 22-16d | 7160 | 18200 | 12865 |
| | | | | | | | | HGU7.25-SDS ³ | 5 1/4 | 36-SDS 1/4x2 1/2 | 24-SDS 1/4x2 1/2 | 9300 | 20320 | 18020 |
| 16 | SCL7.25/16 | 6 | 10-16d | 12-16d | 2345 | 23680 | 13025 | HGUS7.25/14 | 4 | 66-16d | 22-16d | 7160 | 18200 | 12865 |
| | | | | | | | | HHGU7.25-SDS ³ | 5 1/4 | 44-SDS 1/4x2 1/2 | 28-SDS 1/4x2 1/2 | 11590 | 26665 | 23465 |
| 18 | SCL7.25/18 | 6 | 10-16d | 12-16d | 2345 | 23680 | 13025 | HGUS7.25/14 | 4 | 66-16d | 22-16d | 7160 | 18200 | 12865 |
| | | | | | | | | HHGU7.25-SDS ³ | 5 1/4 | 44-SDS 1/4x2 1/2 | 28-SDS 1/4x2 1/2 | 11590 | 26665 | 23465 |

1. See notes on page 8.

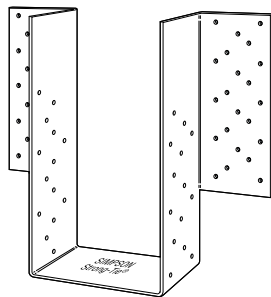

HHGU

HGU – 7 gauge
HHGU – 3 gauge
 The GU hangers are a high-capacity girder hanger designed for situations where the header and joist are flush at top.

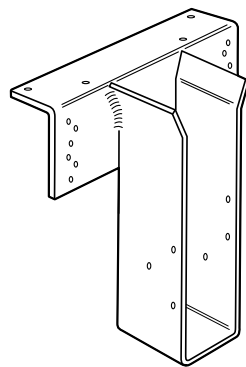

GLTV

GLTV & HGLTV – Top flange – 3 gauge
 Stirrup – 7 gauge
 This welded series provides high load carrying capacity and design flexibility and versatility. May be sloped, skewed and modified in other ways, and may be welded to steel I-beams. The GLTV may be used on 4x nailers.

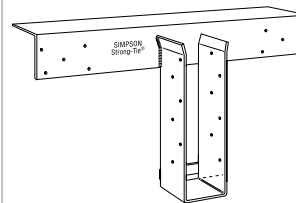

SCL

SCL – Top flange – 1/4 or 3/8 hot rolled angle
 Stirrup – 3 gauge
 This series offers high load capacities. The large top flange distributes the load to the carrying member.

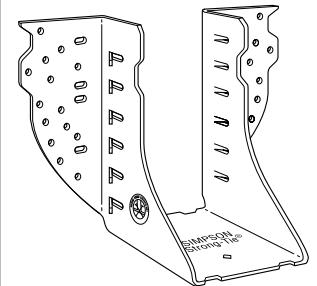

HGUS

HGUS – 12 gauge
HHUS – 14 gauge
 Features double shear nailing for high strength and lowest installed cost due to the reduced nail quantity requirement. Not suitable for use with I-joists.

GENERAL CONNECTOR INSTALLATION



Top Flange Hangers

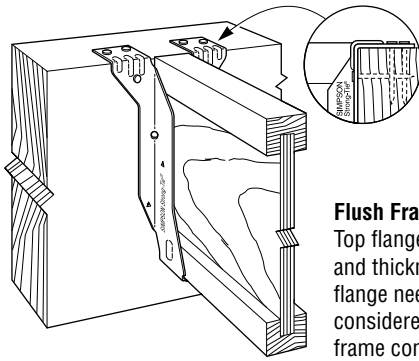

Flush Framing
Top flange configuration and thickness of top flange need to be considered for flush frame conditions.

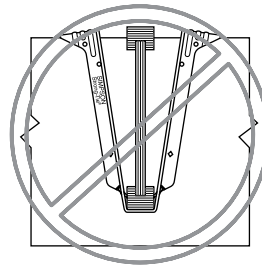

Hanger Over-Spread
If the hanger is over-spread, it can raise the I-Joist above the header and may cause uneven surfaces and squeaky floors.

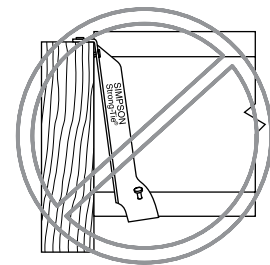

Hanger Not Plumb
A hanger "kicked out" from the header can cause uneven surfaces and squeaky floors.

Wood Nailers

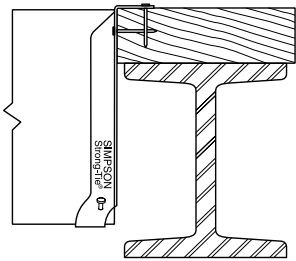

Correct Attachment

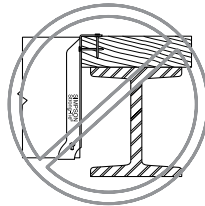

Nailer Too Wide
The loading may cause cross-grain bending. As a general rule, the maximum allowable overhang is 1/4", depending on nailer thickness.

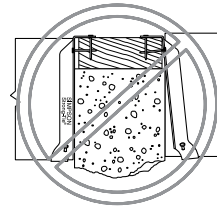

Nailer Too Narrow
A maximum mismatch of 1/8" for normal installations is acceptable.

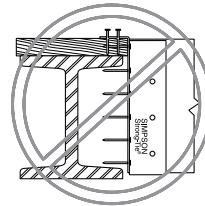

Nailer Too Thin and the wrong hanger for a nailer application.

Nail Hole Shapes

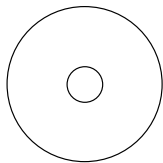

Round Holes
All holes must be filled except for the THAI adjustable height hanger. Refer to load tables for THAI nail quantities.

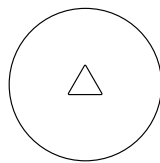

Triangle Holes
Provided on some products in addition to round holes. Round and triangle holes must be filled to achieve the published maximum load value.

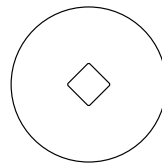

Diamond Holes
Optional holes to temporarily secure connectors to the member during installation.

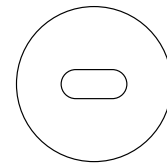

Obround Holes
Used to provide easier nailing access in tight locations. All holes must be filled except for the LSSU hanger when skewed. Refer to load tables for LSSU nail quantities.

Toe Nailed I-Joist

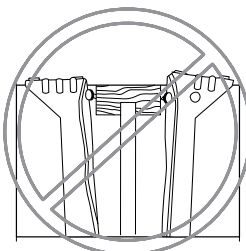

Toe nailing causes squeaks and improper hanger installations. **Do not toe nail I-joists prior to installing either top flange or face mount hangers.**

Double Shear Nailing

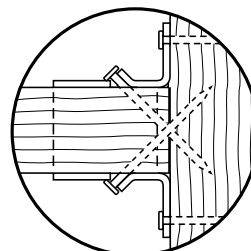

The nail is installed into joist and header, distributing load through two points on each nail for greater strength.

GENERAL CONNECTOR INSTALLATION

IUS Installation Sequence

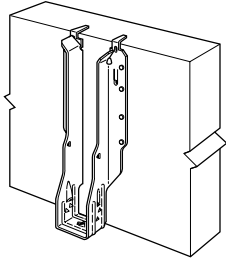

STEP 1
Attach the IUS to the header

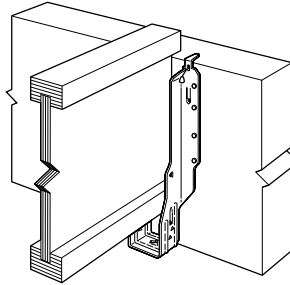

STEP 2
Slide the I-joint into the IUS until it rests above the large teardrop.

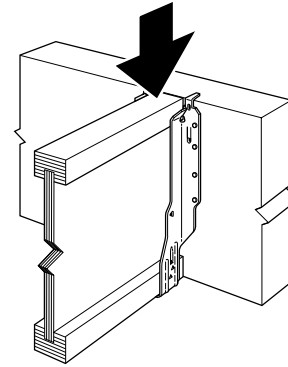

STEP 3
Firmly push or snap I-joint fully into the seat of the IUS.

LT and LF Screw Installation

Use 8 gauge (0.164" diameter) x 1 1/4" wood screw (#8x1 1/4") to secure joist to hanger.

To avoid stripping of the bottom chord screw hole, DO NOT over tighten screw.

Use specified screw to seat joist into hanger (required only for LF and LT hangers).

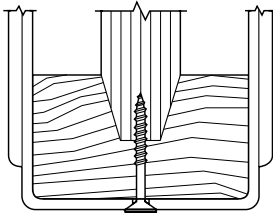

Alternate Uplift Option for IUS

This installation works for I-joists with 1 5/16" or greater depth of bottom flange. Install Simpson's SD8x1.25 tapping screw through the diamond hole in the bottom of the seat.

| Model No. | Joist Fasteners | Uplift | |
|-----------|---|----------|-----------|
| | | DF (115) | SPF (115) |
| IUS | Simpson SD8x1.25 Tapping Screw ¹ | 250 | 215 |

- Any #8x1.25 self-drilling screw may be used.
- Loads are in pounds.

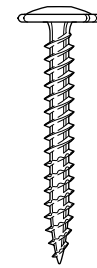

SD8x1.25
(Actual Size)

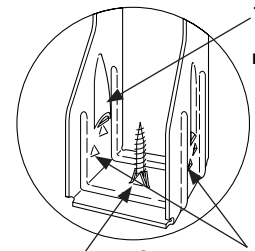

Snap-In Teardrop
No nails required!

The Strong-Grip™ seat secures I-joists in position without joist nails

Starburst detail allows secure seating of joist.

VPA Installation

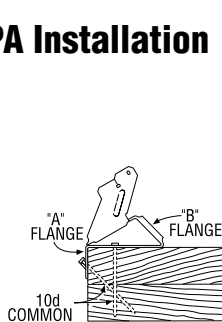

STEP 1
Install top nails and face PAN nails in "A" flange to outside wall top plate.

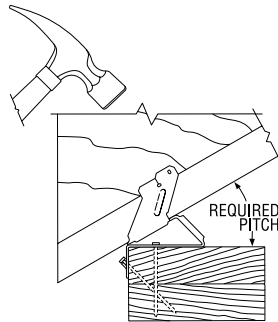

STEP 2
Seat rafter with a hammer, adjusting "B" flange to the required pitch.

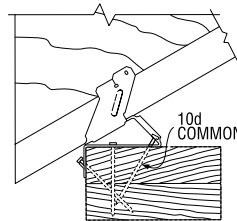

STEP 3
Install "B" flange nails in the obround nail holes, locking the pitch.

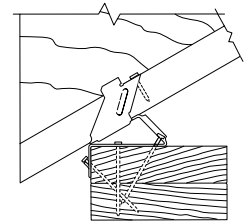

STEP 4
Bend tab with hammer and install nail into tab nail hole. Hammer nail in at approx. 45° angle to limit splitting.

LSSU Installation

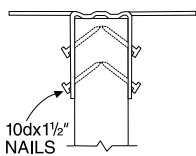

1. Nail hanger to slope-cut joist, installing seat nail first. No bevel necessary for skewed installation.

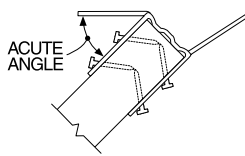

2. Skew flange to form acute angle. Bend other flange back. Bend along the centerline of slots. Bend one time only.

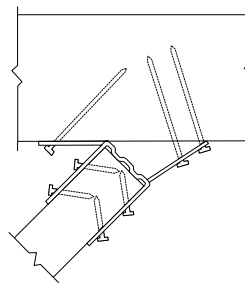

3. Attach hanger to header, acute angle first. Install nails at an angle.

THAI Minimum Nailing

MINIMUM OF 2 1/2" OF TOP FLANGE MATERIAL FOR MINIMUM NAILING CONFIGURATION

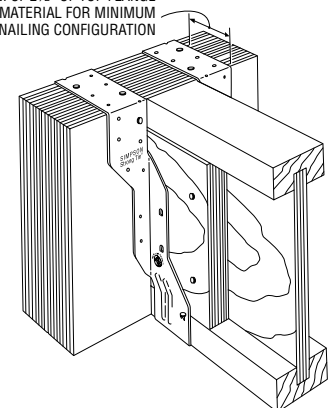

GENERAL CONNECTOR INSTALLATION



TB - Tension Bridging

| Joist Height | Joist Spacing (Inches) | | | | | | | | |
|--------------|------------------------|------|------|------|------|------|------|------|------|
| | 12 | 16 | 19.2 | 24 | 30 | 32 | 36 | 42 | 48 |
| 9½ | TB20 | TB27 | TB27 | TB30 | TB36 | TB36 | TB42 | TB48 | TB54 |
| 11⅞ | TB20 | TB27 | TB27 | TB30 | TB36 | TB36 | TB42 | TB48 | TB54 |
| 14 | TB27 | TB27 | TB27 | TB36 | TB36 | TB42 | TB42 | TB48 | TB54 |
| 16 | TB27 | TB27 | TB30 | TB36 | TB42 | TB42 | TB42 | TB48 | TB54 |

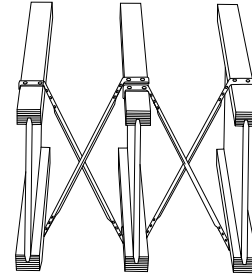

Typical TB Installation

VPA - Variable Pitch Connectors

| Joist Width | Model No. | Fasteners | | Factored Resistances | | | | Lateral (115) | | | |
|-------------|-----------|-----------|----------|----------------------|-----|----------------|------|----------------|----------------|----------------|----------------|
| | | Top Plate | Rafter | Uplift (115) | | Download (100) | | DF | | SPF | |
| | | | | DF | SPF | DF | SPF | F ₁ | F ₂ | F ₁ | F ₂ |
| 2⅝ | VPA35 | 9-10d | 2-10dx1½ | 545 | 390 | 1785 | 1785 | 625 | 415 | 615 | 415 |
| 2½ | VPA3 | 9-10d | 2-10dx1½ | 545 | 390 | 1785 | 1785 | 625 | 415 | 615 | 415 |
| 3½ | VPA4 | 11-10d | 2-10dx1½ | 545 | 390 | 1785 | 1785 | 625 | 415 | 615 | 415 |

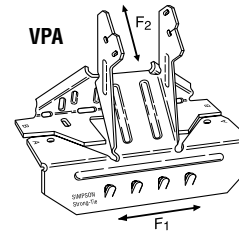

1. VPA's are not appropriate for applications that require more than 2" of bearing, such as intermediate supports.

VPA – 18 gauge
This variable pitch connector allows a sloped beam to sit on a top plate without having to notch, birdmouth, bevel, or toe nail. It also provides uplift capacity. Adjustable from 3:12 to 12:12 pitch.

STRONG-DRIVE® SCREW INSTALLATION FOR LVL

INSTALLATION

- Hex washer head allows for easy driving.
- Built-in reamer and the 4CUT™ tip means no pre-drilling required.
- See illustrations for SDS positioning on different assemblies.
- Install with high-torque, low speed drill (5 amp+).
- Do not over-drive the SDS screws.

DESIGN

- This document uses LVL values (SG = 0.50) and (SG = 0.42). Verify with LVL manufacturer specifications.
- Uniform loads in the table represent the capacity of the fasteners. The capacity of the LVL beam may be less and should be checked by a qualified designer or with the manufacturer's literature.
- The designer shall specify the location of all screws (stagger screws on opposite faces). Minimum recommended spacing—Wide Face: end distance 4", edge distance 1½", spacing parallel to grain 4", spacing perpendicular to grain 2½".

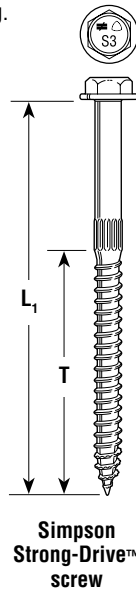

Screw Dimensions

| Model No. | L ₁ (in.) | T (in.) | Head Stamp |
|-----------|----------------------|---------|------------|
| SDS25312 | 3½ | 2¼ | S3.5 |
| SDS25412 | 4½ | 2¾ | S4.5 |
| SDS25600 | 6 | 3¼ | S6 |

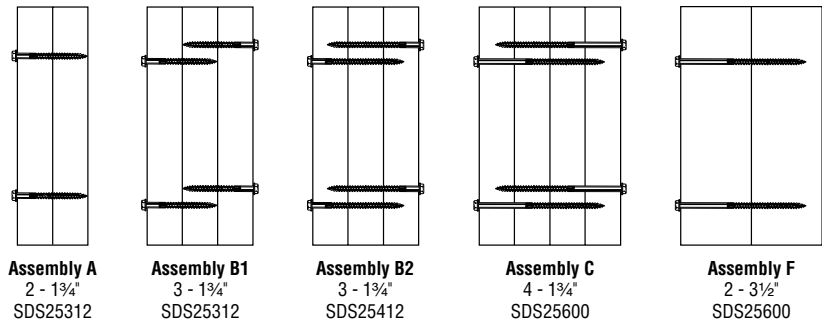

| Assembly | SDS Screw Length | Side Member Thickness | Maximum Factored Uniform Load Applied to Outer Member (plf) | | | | | |
|----------------------|------------------|-----------------------|---|--------|--------------|--------|--------------|--------|
| | | | SDS @12" o/c | | SDS @16" o/c | | SDS @24" o/c | |
| | | | 2-Rows | 3-Rows | 2-Rows | 3-Rows | 2-Rows | 3-Rows |
| LVL (SG=0.50) | | | | | | | | |
| A | 3½ | 1¾ | 1220 | 1830 | 915 | 1370 | 610 | 915 |
| B1 | 3½ | 1¾ | 915 | 1370 | 685 | 1030 | 455 | 685 |
| B2 | 4½ | 1¾ | 1455 | 2180 | 1090 | 1635 | 725 | 1090 |
| C | 6 | 1¾ | 1040 | 1560 | 780 | 1170 | 520 | 780 |
| F | 6 | 3½ | 1220 | 1830 | 915 | 1375 | 610 | 915 |
| LVL (SG=0.42) | | | | | | | | |
| A | 3½ | 1¾ | 1020 | 1530 | 765 | 1150 | 510 | 765 |
| B1 | 3½ | 1¾ | 765 | 1145 | 575 | 860 | 380 | 575 |
| B2 | 4½ | 1¾ | 1225 | 1835 | 920 | 1375 | 610 | 920 |
| C | 6 | 1¾ | 800 | 1200 | 600 | 900 | 400 | 600 |
| F | 6 | 3½ | 1040 | 1560 | 780 | 1170 | 520 | 780 |

1. If 7" wide beams are not equally loaded on each side, the load from the lesser side should be at least 25% of the opposite side.
2. Quantity and spacing of screws in table are for each screw head side of the assembly as shown in the Assembly figures above.
3. The designer shall ensure that adequate lateral bracing is provided to prevent displacement of the beam due to the torsion created by the structural members framing into the side of the beam assembly.

Refer to the current Canadian Wood Construction Connectors catalogue for General Notes, Warranty Information and other important information, including Terms and Conditions of Sale, Building Code Evaluation listings and Corrosion Resistance.

© 2008 Simpson Strong-Tie Company Inc. • P.O. Box 10789, Pleasanton, CA 94588

CSG-LPCAN09 2/09 exp. 1/11 12/11

800-999-5099
www.strongtie.com