

CONNECTOR SELECTION GUIDE



FOR USE WITH PRODUCTS
MANUFACTURED BY:



Superior I Beam™



This guide lists popular options for Simpson Strong-Tie hangers used with engineered wood products. Not all available hanger and installation combinations are listed. Use in conjunction with the current Simpson Strong-Tie Canadian **Wood Construction Connectors** catalogue for detailed hanger information.



LIMIT
STATES
DESIGN

800-999-5099
www.strongtie.com

DISTRIBUTED BY:

SINGLE I-JOISTS – Canadian/Factored Resistance (lbs)



Joist Height	Top Flange						Snap-In						Face Mount								
	Model	B Dim	Fastener Type		Uplift (115)	Down Load DF	Down Load SPF	Model	B Dim	Fastener Type		Uplift (115)	Down Load DF	Down Load SPF	Model	B Dim	Fastener Type		Uplift (115)	Down Load DF	Down Load SPF
			Header	Joist						Header	Joist						Header	Joist			
SIB 30, SIB 31																					
Joist Width = 2 1/2"																					
9 1/2	LT259	2	6-10d	1-#8x1 1/4ws	100	2620	1725	IUS2.56/9.5	2	8-10d	—	105	2385	1700	LF259	2	10-10d	1-#8x1 1/4ws	100	2525	2155
11 1/8	LT251188	2	6-10d	1-#8x1 1/4ws	100	2620	1725	IUS2.56/11.88	2	10-10d	—	105	2565	1835	LF2511	2	12-10d	1-#8x1 1/4ws	100	2880	2270
12 1/2	LBV2.56X5	2 1/2	10-10d	2-10dx1 1/2	310	3905	3125	No IUS for this depth.						LF2511	2	12-10d	1-#8x1 1/4ws	100	2880	2270	
14	LT2514	2	6-10d	1-#8x1 1/4ws	100	2620	1725	IUS2.56/14	2	12-10d	—	105	2565	1835	LF2514	2	14-10d	1-#8x1 1/4ws	100	3235	2385
16	LT2516	2	6-10d	1-#8x1 1/4ws	100	2620	1725	IUS2.56/16	2	14-10d	—	105	2725	1950	MIU2.56/16	2 1/2	24-16d	2-10dx1 1/2	270	4930	3485
SIB 41																					
Joist Width = 3 1/2"																					
9 1/2	LT359	2	6-10d	2-#8x1 1/4ws	100	2620	1725	IUS3.56/9.5	2	10-10d	—	105	2375	1695	LF359	2	10-10d	2-#8x1 1/4ws	100	2525	2155
11 1/8	LT351188	2	6-10d	2-#8x1 1/4ws	100	2620	1725	IUS3.56/11.88	2	12-10d	—	105	2375	1695	LF3511	2	12-10d	2-#8x1 1/4ws	100	2880	2270
12 1/2	LBV3.56X5	2 1/2	10-10d	2-10dx1 1/2	310	3905	3125	No IUS for this depth.						LF3511	2	12-10d	2-#8x1 1/4ws	100	2880	2270	
14	LT3514	2	6-10d	2-#8x1 1/4ws	100	2620	1725	IUS3.56/14	2	12-10d	—	105	2375	1695	LF3514	2	14-10d	2-#8x1 1/4ws	100	3235	2385
16	LT3516	2	6-10d	2-#8x1 1/4ws	100	2620	1725	IUS3.56/16	2	14-10d	—	105	2375	1695	MIU3.56/16	2 1/2	24-16d	2-10dx1 1/2	270	4930	3485

Joist Height	45° Skew						Adjustable Height						Field Slope & Skew								
	Model	B Dim	Fastener Type		Uplift (115)	Down Load DF	Down Load SPF	Model	B Dim	Fastener Type		Uplift (115)	Down Load DF	Down Load SPF	Model	B Dim	Fastener Type		Uplift (115)	Down Load DF	Down Load SPF
			Header	Joist						Header	Joist						Header	Joist			
SIB 30, SIB 31																					
Joist Width = 2 1/2"																					
9 1/2	SUR/L2.56/9	3 3/16	14-16d	2-10dx1 1/2	385	3945	2780	THAI322	2 1/4	6-10d	2-10dx1 1/2	—	2740	2075	LSSUH310	3 1/2	14-16d	12-10dx1 1/2	1220	2620	1850
11 1/8	SUR/L2.56/11	3 3/16	16-16d	2-10dx1 1/2	385	3945	2780	THAI322	2 1/4	6-10d	2-10dx1 1/2	—	2740	2075	LSSUH310	3 1/2	14-16d	12-10dx1 1/2	1220	2620	1850
12 1/2	SUR/L2.56/11	3 3/16	16-16d	2-10dx1 1/2	385	3945	2780	THAI322	2 1/4	6-10d	2-10dx1 1/2	—	2740	2075	LSSUH310	3 1/2	14-16d	12-10dx1 1/2	1220	2620	1850
14	SUR/L2.56/14	3 3/16	18-16d	2-10dx1 1/2	385	3945	2780	THAI322	2 1/4	6-10d	2-10dx1 1/2	—	2740	2075	LSSUH310	3 1/2	14-16d	12-10dx1 1/2	1220	2620	1850
16	SUR/L2.56/14	3 3/16	18-16d	2-10dx1 1/2	385	3945	2780	See Wood Construction Connectors Catalogue for hanger selection.						See Wood Construction Connectors Catalogue for hanger selection.							
SIB 41																					
Joist Width = 3 1/2"																					
9 1/2	SUR/L410	2 5/8	14-16d	6-16d	1395	4065	2875	THAI422	2 1/4	6-10d	2-10dx1 1/2	—	2740	2075	LSSU410	3 1/2	14-16d	12-10dx1 1/2	1220	3055	2160
11 1/8	SUR/L410	2 5/8	14-16d	6-16d	1395	4065	2875	THAI422	2 1/4	6-10d	2-10dx1 1/2	—	2740	2075	LSSU410	3 1/2	14-16d	12-10dx1 1/2	1220	3055	2160
12 1/2	SUR/L414	2 1/2	18-16d	8-16d	1555	4095	2895	THAI422	2 1/4	6-10d	2-10dx1 1/2	—	2740	2075	LSSU410	3 1/2	14-16d	12-10dx1 1/2	1220	3055	2160
14	SUR/L414	2 1/2	18-16d	8-16d	1555	4095	2895	THAI422	2 1/4	6-10d	2-10dx1 1/2	—	2740	2075	LSSU410	3 1/2	14-16d	12-10dx1 1/2	1220	3055	2160
16	SUR/L414	2 1/2	18-16d	8-16d	1555	4095	2895	See Wood Construction Connectors Catalogue for hanger selection.						See Wood Construction Connectors Catalogue for hanger selection.							

- Shaded hangers require web stiffeners at joist ends. Web stiffeners may be required for non-shaded hangers by others.
- THAI hangers require a minimum of 4 top and 2 face nails installed. THAI-2 must be special ordered, specify hanger seat width between 3 1/8" and 5 1/8"
- LSSU.12 skew options must be factory ordered.
- Skewed option must be special ordered. Specify skew angle and direction (i.e. HU410-2X, SKR 45°).
- Special order depth required. Specify depth needed (i.e. LBV5.12X H=12 1/2").
- The B Dim is the depth of the hanger seat.
- Loads listed assume a solid header. See page 4 for I-Joist headers.

Nail Callout	Specified Nail
8d	2 1/2" common wire
10d	3" common wire
16d	3 1/2" common wire

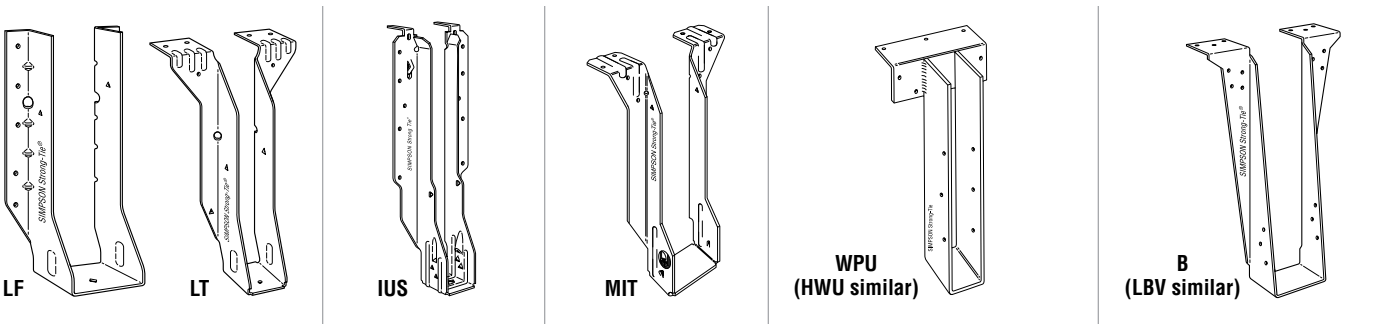

LF – 18 gauge
LT – 18 gauge
 The LF and LT series feature fast and easy installation. No web stiffeners required and only one screw secures joist in hanger.

IUS – 18 gauge
 The IUS is a hybrid hanger that incorporates the advantages of face-mount and top-flange hangers. Joist nails are not required.

MIT – 16 gauge
 The MIT's Positive Angle Nailing helps minimize splitting of the I-joists' bottom flange. Features uplift capacity and extended seat design.

W, WI – Top flange – 12 gauge; Stirrup – 12 gauge
WP, WPI, WPU – Top flange – 7 gauge; Stirrup – 12 gauge
HWU – Top flange – 3 gauge Stirrup – 10 gauge
 This welded series offers the greatest design flexibility and versatility, and a large selection of sizes. Suitable for welded and nailer applications, and modifications including slopes and skews.

B – 12 gauge
LBV – 14 gauge
 The B series offers versatility for I-joists and SCL lumber. Enhanced load capacity widens the range of applications for these hangers.

 The LBV is designed especially for use with multiple ply headers 1 1/2" to 1 3/4" thick, and may be used for weld-on applications.

DOUBLE I-JOISTS – Canadian/Factored Resistance (lbs)

Joist Height	Top Flange						Face Mount						45° Skew								
	Model	B Dim	Fastener Type		Uplift (115)	Down Load	Model	B Dim	Fastener Type		Uplift (115)	Down Load	Model	B Dim	Fastener Type		Uplift (115)	Down Load			
			Header	Joist					Header	Joist					Header	Joist			Header	Joist	
Double SBI 30, SBI 31																					
Joist Width = 5"																					
9½	MIT39.5-2	2½	8-16d	2-10dx1½	380	3480	2415	MIU5.12/9	2½	16-16d	2-10dx1½	270	4550	3215	HSUR/L5.12/9	2½	12-16d	2-10dx1½	195	2995	2350
11½	MIT311.88-2	2½	8-16d	2-10dx1½	380	3480	2415	MIU5.12/11	2½	20-16d	2-10dx1½	270	4550	3215	HSUR/L5.12/11	2½	16-16d	2-10dx1½	195	4195	2965
12½	LBV5.12X ⁵	2½	10-16d	2-10dx1½	310	3905	3125	MIU5.12/11	2½	20-16d	2-10dx1½	270	4550	3215	HSUR/L5.12/11	2½	16-16d	2-10dx1½	195	4195	2965
14	MIT314-2	2½	8-16d	2-10dx1½	380	3480	2415	MIU5.12/14	2½	22-16d	2-10dx1½	270	4930	3485	HSUR/L5.12/14	2½	20-16d	2-10dx1½	195	4195	2965
16	MIT5.12/16	2½	8-16d	2-10dx1½	380	3480	2415	MIU5.12/16	2½	24-16d	2-10dx1½	270	4930	3485	HSUR/L5.12/16	2½	24-16d	2-10dx1½	195	4195	2965
Double SBI 41																					
Joist Width = 7"																					
9½	B7.12/9.5	2½	14-16d	6-16d	1170	5940	3910	HU410-2	2½	18-16d	8-16d	1865	5780	4670	HU410-2X ⁴	2½	18-16d	8-16d	1400	3755	3035
11½	B7.12/11.88	2½	14-16d	6-16d	1170	5940	3910	HU412-2	2½	22-16d	8-16d	1865	5780	4670	HU412-2X ⁴	2½	22-16d	8-16d	1400	3755	3035
12½	B7.12/12X ⁵	2½	14-16d	6-16d	1170	5940	3910	HU412-2	2½	22-16d	8-16d	1865	5780	4670	HU412-2X ⁴	2½	22-16d	8-16d	1400	3755	3035
14	B7.12/14	2½	14-16d	6-16d	1170	5940	3910	HU414-2	2½	26-16d	12-16d	2685	7025	5780	HU414-2X ⁴	2½	26-16d	12-16d	2010	4565	3755
16	B7.12/16	2½	14-16d	6-16d	1170	5940	3910	HU414-2	2½	26-16d	12-16d	2685	7025	5780	HU414-2X ⁴	2½	28-16d	12-16d	2010	4565	3755

Joist Height	Adjustable Height						Field Slope & Skew							
	Model	B Dim	Fastener Type		Uplift (115)	Down Load	Model	B Dim	Fastener Type		Uplift (115)	Down Load		
			Header	Joist					Header	Joist				
Double SBI 30, SBI 31														
Joist Width = 5"														
9½	THAI-2 ²	2½	6-10d	2-10dx1½	—	2935	2935	LSU5.12 ³	3½	24-16d	16-10dx1½	910	2600	1835
11½	THAI-2 ²	2½	6-10d	2-10dx1½	—	2935	2935	LSU5.12 ³	3½	24-16d	16-10dx1½	910	2600	1835
12½	THAI-2 ²	2½	6-10d	2-10dx1½	—	2935	2935	LSU5.12 ³	3½	24-16d	16-10dx1½	910	2600	1835
14	THAI-2 ²	2½	6-10d	2-10dx1½	—	2935	2935	LSU5.12 ³	3½	24-16d	16-10dx1½	910	2600	1835
16	See Wood Construction Connectors Catalogue for hanger selection.						See Wood Construction Connectors Catalogue for hanger selection.							
Double SBI 41														
Joist Width = 7"														
9½	See Wood Construction Connectors Catalogue for hanger selection.						See Wood Construction Connectors Catalogue for hanger selection.							
11½	See Wood Construction Connectors Catalogue for hanger selection.						See Wood Construction Connectors Catalogue for hanger selection.							
12½	See Wood Construction Connectors Catalogue for hanger selection.						See Wood Construction Connectors Catalogue for hanger selection.							
14	See Wood Construction Connectors Catalogue for hanger selection.						See Wood Construction Connectors Catalogue for hanger selection.							
16	See Wood Construction Connectors Catalogue for hanger selection.						See Wood Construction Connectors Catalogue for hanger selection.							

Variable Pitch					
Model	B Dim	Fastener Type		Uplift (115)	Down Load
		Header	Joist		
IB400 and IB600					
Joist Width = 2½"					
VPA3	2½	9-10d	2-10dx1½	390	1785
IB800 and IB900					
Joist Width = 3½"					
VPA4	2½	11-10d	2-10dx1½	390	1785

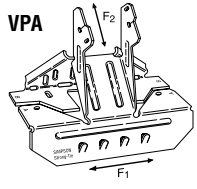

VPA – 18 gauge
This variable pitch connector allows a sloped beam to sit on a top plate without having to notch, birdmouth, bevel, or toe nail. It also provides uplift capacity. Adjustable from 3:12 to 12:12 pitch.

1. See notes on page 2.

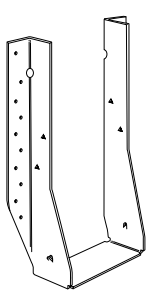

MIU

MIU – 16 gauge
The MIU series features 16 gauge steel and extra nailing for higher loads.

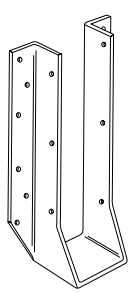

HU

HU – 14 gauge
The HU series features uplift capacity and a large selection of sizes and load ranges. HU hangers have triangle holes that can be filled for increased loads. Web stiffeners required when used with I-joists.

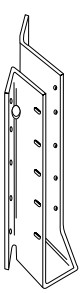

SUL

SUR/L – 16 gauge
HSUR/L – 14 gauge
All models are skewed 45°. Normally accommodates a 40° - 50° skew. The installation of these hangers does not require a beveled end cut. Web stiffeners required when used with I-joists.

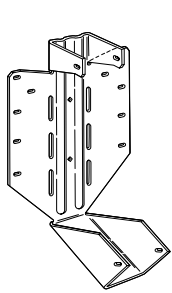

LSSU

LSSUH310 and LSSU410 – 16 gauge
LSSU models provide uplift capacity and can be field sloped and/or skewed to 45°. Web stiffeners required when used with I-joists.

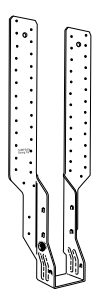

THAI

THAI – 18 gauge
THAI-2 – 14 gauge
This hanger has extra long straps and can be field-formed to give height adjustability and top flange hanger convenience. Positive angle nailing helps minimize splitting of the I-joist's bottom flange. Minimum nailing is shown in the table above. Strap must be field-formed over the top of the header by a minimum of 2½". Web stiffeners required when used with I-joists.

General Notes

- See current Canadian *Wood Construction Connectors* catalogue for Important Information and General Notes sections and for hanger models, joist sizes, and header situations not shown.
- Loads listed address hanger/header/fastener limitations assuming header material is Douglas Fir-Larch or Spruce Pine Fir. For LVL headers made primarily of Douglas Fir/Southern Pine, use the values found in the DF column. For LVL headers made primarily from Spruce Pine Fir or similar less dense veneers, use the values found in the SPF column. Loads are in pounds. Joist reaction should be checked by a qualified designer to ensure proper hanger selection.
- Factored uplift resistances have been increased by 15% for earthquake and wind loading with no further increase allowed. Reduce loads according to code for normal duration loading such as cantilever construction.
- For this publication, carrying members are assumed to be at least 5½" tall. The horizontal thickness of the carrying member must be at least the length of nail being used or the top flange dimension, whichever is greater. Exception: narrower carrying members may be used with face mount hangers but the horizontal thickness must be at least 1¼" for 10d nails; 2" for 16d nails. Clinch nails on back side.
- THAI hangers in this publication are based on a "top flange" installation and require that the carrying member have a horizontal thickness of at least 2½" backer blocks are required when the header is an I-joist.
- All nails shown are common nails unless otherwise noted.

I-Joist Headers

I-Joist Headers: When supporting one I-joist from another, backer blocks must be used. Backer blocks are to be made from plywood, OSB, or dimension lumber. The thickness of a backer block should be the same thickness as the void in the side of the I-joist and a minimum of 12" wide. Attach with 10-10d common nails clinched as necessary, prior to installing the hanger. For Top Flange hangers, install backer blocks tight to top flange. For Face Mount hangers, install backer blocks tight to bottom flange. Use 10dx1½" nails for all Top Flange hangers attached to an I-joist header. See table for factored resistance.

For face mount hangers using 10d nails with headers less than 1¼" wide horizontally but at least 1½" wide, apply a reduction factor of 0.77 to all table loads.

Model	I-Joist Header Flange Material
	SPF
LF	1695
MIT	1900
LBV	2200
BA	2420

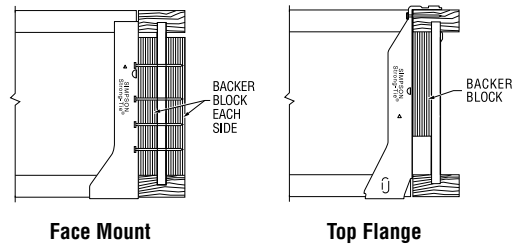

VPA Installation

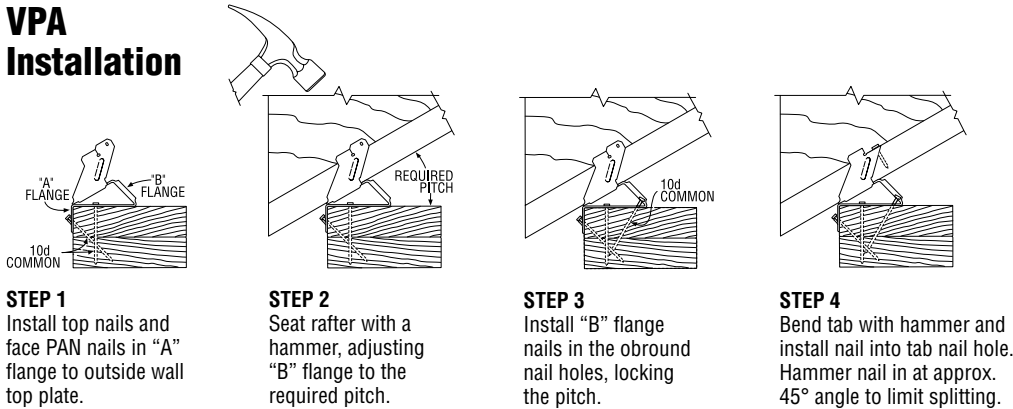

LSSU Installation

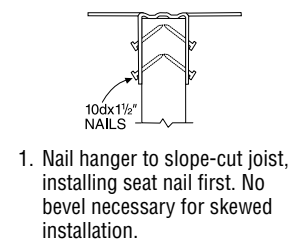

- Nail hanger to slope-cut joist, installing seat nail first. No bevel necessary for skewed installation.
- Skew flange to form acute angle. Bend other flange back. Bend along the centerline of slots. Bend one time only.

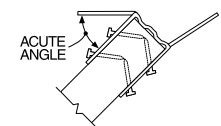

IUS Installation Sequence

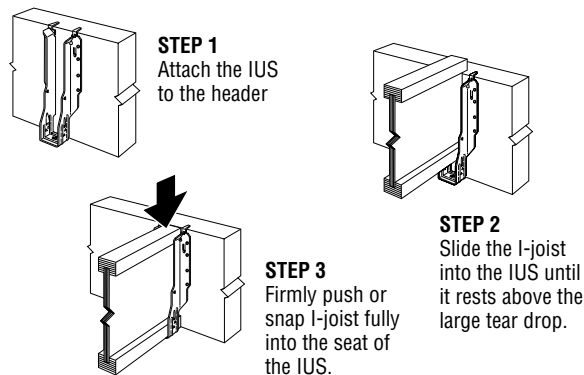

LF/LT Screw Installation

Use 8 gauge (0.164" diameter) x 1¼" wood screw (#8x1¼") to secure joist to hanger. To avoid stripping of the bottom chord screw hole, DO NOT over tighten screw. Use specified screw to seat joist into hanger (required only for LF and LT hangers).

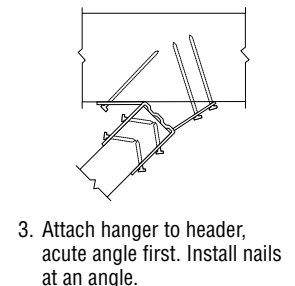
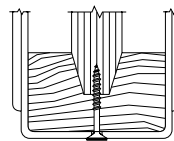

- Attach hanger to header, acute angle first. Install nails at an angle.